

Type 1 and 2 Cooling Tower Nozzles, Crossflow

IMPORTANT

Refer to Technical Data Sheet TFP2300 for warnings pertaining to regulatory and health information. Always refer to Technical Data Sheet TFP700 for the "INSTALLER WARNING" that provides cautions with respect to handling and installation of sprinkler systems and components. Improper handling and installation can permanently damage a sprinkler system or its components and cause the sprinkler to fail to operate in a fire situation or cause it to operate prematurely.

Scan the QR code or enter the URL in a web browser to access the most up-to-date electronic version of this document. Data rates may apply.



docs.jci.com/tycofire/tfp830

General Description

The TYCO Type 1 and 2 Cooling Tower Nozzles are intended for use in open head, water spray deluge fire protection systems for crossflow cooling towers having combustible fill sections. They discharge water in a relatively narrow, elongated spray pattern. This discharge characteristic is specifically required for locating the nozzles under the distribution basin, on either the louver or drift eliminator side, and directing water discharge horizontally between the joist channels.

The Type 1 Nozzle is designed for use in crossflow cooling towers with diffusion decks, and the Type 2 Nozzle is designed for use in crossflow cooling towers without diffusion decks. The Waterway of the Type 2 Nozzle is oriented at a slightly lower angle than the Type 1, with respect to the plane of the nozzle frame arms. This results in a more divergent spray pattern vertically, which is required for use in crossflow cooling towers without diffusion decks.

It is recommended that the end user be consulted with respect to the suitability of the materials of construction for any given corrosive environment. The effects of ambient temperature, concentration of chemicals, and gas/chemical velocity, should be considered, at a minimum, along with the corrosive nature to which the sprinklers may be exposed.

The Type 1 and 2 Cooling Nozzle are a re-designation for the Gem Type 1 and 2.

NOTICE

The Type 1 and 2 Cooling Tower Nozzles described herein must be installed and maintained in compliance with this document and with the applicable standards of the NATIONAL FIRE PROTECTION ASSOCIATION (NFPA), in addition to the standards of any authorities having jurisdiction. Failure to do so may impair the performance of these devices.

The owner is responsible for maintaining their fire protection system and devices in proper operating condition. Contact the installing contractor or product manufacturer with any questions.



Technical Data

Approvals

The plain finish bronze Types 1 and 2 Cooling Tower Nozzles are UL Listed and FM Approved.

The plain finish stainless steel Types 1 and 2 Cooling Tower Nozzles are UL Listed.

Maximum Working Pressure

175 psi (12,1 bar)

Discharge Coefficient

2.9 GPM/psi^{1/2} (42,0 LPM/bar^{1/2})

Pipe Thread Connection

3/4 in. NPT

Physical Characteristics

Frame Bronze or Stainless Steel
Waterway Bronze or Stainless Steel

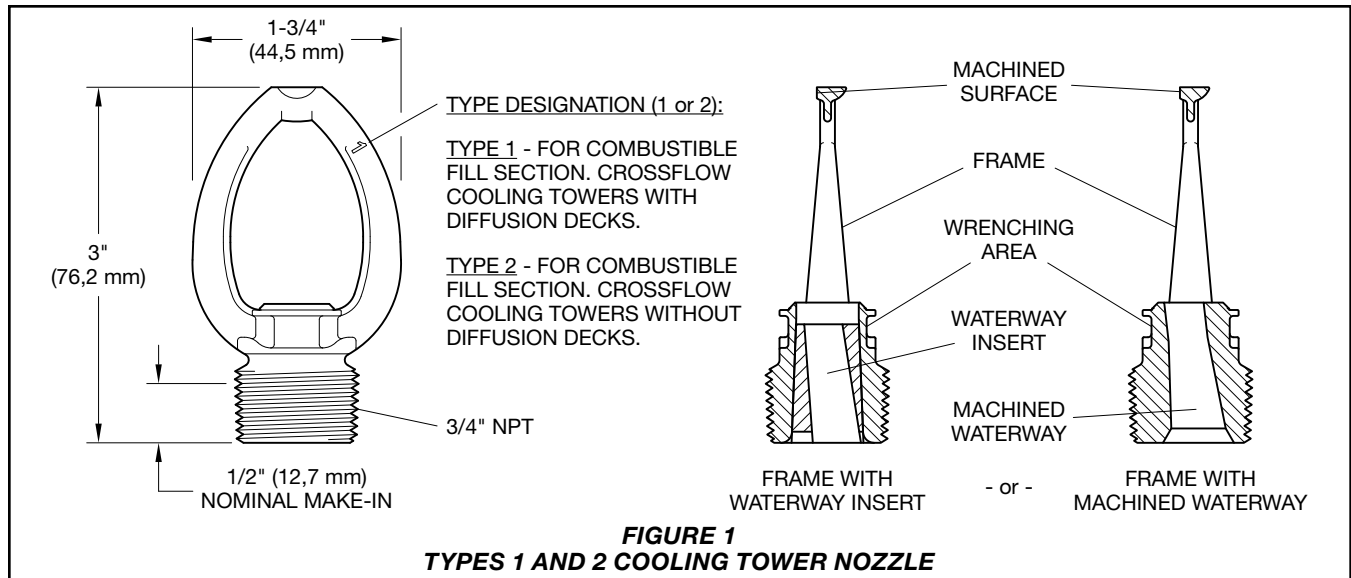

FIGURE 1
TYPES 1 AND 2 COOLING TOWER NOZZLE

Design Criteria

Hydraulic Design

The fire protection system for crossflow cooling towers having combustible fill sections is to provide a minimum application density of 0.50 GPM/ft² (20,4 mm/min) over the fill area. Table A summarizes the water discharge requirements for 24 in. (610 mm) wide joist channels and fill section lengths of 8 ft to 18 ft (2,4 to 5,5 m).

The Types 1 and 2 Cooling Tower Nozzles may be used to cover a maximum width of 24 in. (610 mm). Consequently, when joist channels are wider than 24 in. (610 mm), more than one cooling tower nozzle will be required per channel.

Nozzle Placement

Each cooling tower nozzle must be installed on 1 in. (DN25) swing joint, as shown in Figure 2, since the Nozzle spray characteristics are dependent on the characteristics of the inlet piping. Also, the swing joint facilitates adjusting the Nozzle Projection Angle per Table A.

The cooling tower nozzles must be installed with the plane of their frame arms horizontal, that is, parallel to the distribution basin, and with the machined surface facing upwards as shown in Figure 2.

Main Pipeline Strainers

The waterway of the Type 1 and 2 Cooling Tower Nozzles have a nominal exit diameter of 0.330 in. (8,4 mm); therefore, the use of a main pipeline strainer per NFPA 214 is required, since the nozzle orifice diameter is less than 0.375 in. (9,5 mm).

FILL SECTION LENGTH	WATER DISCHARGE (1)		NOZZLE PROJECTION ANGLE (2)	
	psi (bar)	GPM (LPM)	TYPE 1	TYPE 2
Up to 8 ft (Up to 2,4 m)	10 (0,7)	9 (34,1)	8°	2°
8 ft to 10 ft (2,4 m to 3,0 m)	15 (1,0)	11 (41,6)	8°	2°
10 ft to 12 ft (3,0 m to 3,7 m)	20 (1,4)	13 (49,2)	8°	6°
12 ft to 14 ft (3,7 m to 4,3 m)	26 (1,8)	15 (56,8)	8°	8°
14 ft to 16 ft (4,3 m to 4,9 m)	30 (2,1)	16 (60,6)	8°	8°
16 ft to 18 ft (4,9 m to 5,5 m)	38 (2,6)	18 (68,1)	8°	10°

NOTES
1. Water discharge requirements for a minimum application density of 0.50 GPM/ft² (20,4 mm/min) for cooling towers with 24 in. (610 mm) wide joist channels and fill section lengths of 8 ft to 18 ft (2,4 m to 5,5 m).
2. Nozzle Projection Angle is downward from the horizontal (Ref. Figure 2).

TABLE A
NOZZLE PROJECTION ANGLE
AND WATER DISCHARGE REQUIREMENTS
AS A FUNCTION OF FILL SECTION LENGTH

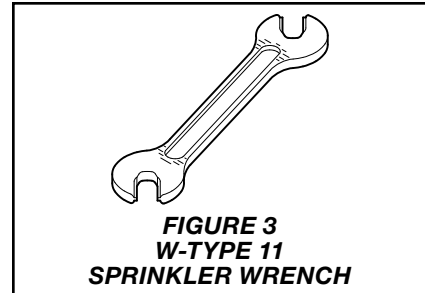
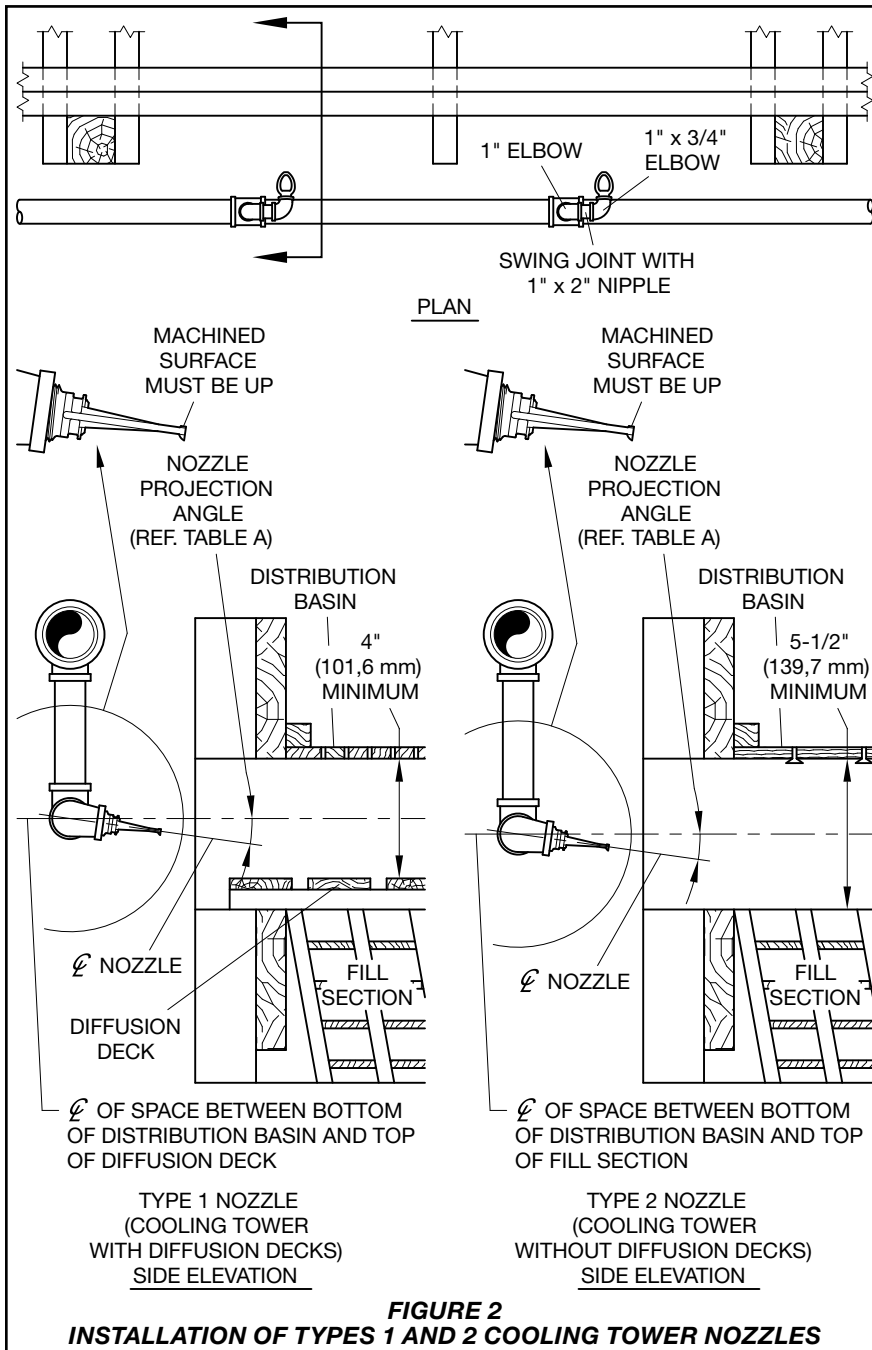

Installation

The TYCO Type 1 and 2 Cooling Tower Nozzles must be installed in accordance with this section.

NOTICE

A leak tight 3/4 in. NPT sprinkler joint should be obtained with a minimum-to-maximum torque of 10 to 20 ft-lb (13,4 to 26,8 N-m). Higher levels of torque may damage the nozzle with consequent leakage or impairment of the nozzle.

Step 1. With pipe thread sealant applied to the pipe threads, hand tighten the nozzle into the nozzle fitting.

Step 2. Tighten the nozzle into the nozzle fitting using only the W-Type 11 Sprinkler Wrench, see Figure 3. With reference to Figure 1, the W-Type 11 Sprinkler Wrench is to be applied to the wrenching area.

The cooling tower nozzles must be installed with the plane of their frame arms horizontal (i.e., parallel to the distribution basin) and with the machined surface facing upwards as shown in Figure 2.

The cooling tower nozzles must be installed with the applicable Nozzle Projection Angle indicated in Table A (according to the fill section length), and as illustrated in Figure 2. It is recommended that a 3/4 in. (DN20) pipe nipple be temporarily installed in the 1 in. x 3/4 in. (DN25 x DN20) reducing elbow, and that an adjustable spirit level be used to set the Nozzle Projection Angle.

Care and Maintenance

The TYCO Type 1 and 2 Cooling Nozzles must be maintained and serviced in accordance with this section.

Before closing a fire protection system main control valve for maintenance work on the fire protection system that it controls, obtain permission to shut down the affected fire protection system from the proper authorities and notify all personnel who may be affected by this action.

Type 1 and 2 Cooling Tower Nozzles must never be painted, plated, coated or altered in any way after leaving the factory; otherwise, the spray performance may be impaired.

Exercise care to avoid damage to the nozzles before, during, and after installation. Replace nozzles damaged by dropping, striking, wrench twist/slip-page, or the like.

Frequent visual inspections are recommended to be initially performed for nozzles installed in potentially corrosive atmospheres to verify the integrity of the materials of construction and finish as they may be affected by the corrosive conditions present for a given installation. Thereafter, annual inspections per NFPA 25 are required.

Water spray fixed systems for cooling towers require regularly scheduled care and maintenance by trained personnel. In addition to inspecting nozzles for proper spray performance during water flow trip tests of the system, it is recommended that nozzles be periodically inspected for broken or missing parts, loading/obstructions, or other evidence of impaired protection. The inspections should be scheduled weekly or as frequently as may be necessary, and corrective action must be taken to ensure that the nozzles will perform as intended in the event of a fire.

The owner is responsible for the inspection, testing, and maintenance of their fire protection system and devices in compliance with this document, as well as with the applicable standards of the NATIONAL FIRE PROTECTION ASSOCIATION (e.g., NFPA 25), in addition to the standards of any other authorities having jurisdiction. Contact the installing contractor or product manufacturer with any questions.

Water spray fixed systems for cooling towers are recommended to be inspected, tested, and maintained by a qualified Inspection Service in accordance with local requirements and/or national code.

Limited Warranty

For warranty terms and conditions, visit www.tyco-fire.com.

Ordering Procedure

Contact your local distributor for availability. When placing an order, indicate the full product name and Part Number (P/N).

Cooling Tower Nozzles

Specify: Type (specify 1 or 2) in a (specify plain finish bronze or stainless steel), P/N (specify):

Bronze

Type 1.....50-081-1-000
Type 2.....50-082-1-001

Stainless Steel

Type 1..... 50-081-0-001
Type 2..... 50-082-0-001

Sprinkler Wrench

Specify: W-Type 11 Sprinkler Wrench, P/N 56-452-1-001



Worldwide
Contacts | www.tyco-fire.com

TFP830

Change History Appendix

ISSUE DATE	NOTES
08-22	Page 1, added QR code and URL to allow convenient access to electronic version from printed document; Page 4, changed corporate address and telephone number to 1467 Elmwood Avenue, Cranston, RI 02910 Telephone +1-401-781-8220, formerly 1400 Pennbrook Parkway, Lansdale, PA 19446 Telephone +1-215-362-0700.
08-18	Updated Tyco® branding and document format; Added Johnson Controls copyright; Added disclaimer stating specifications and information subject to change without notice; Added reference to Regulatory and Health Warning Technical Data Sheet TFP2300.
02-17	Updated limited warranty information.
01-12	Added UL Listing for stainless steel plain finish.
04-06	New Technical Data Sheet TFP830 describes Types 1 and 2 Cooling Tower Nozzles.