

Series DS-ECC Dry Type Sprinklers 5.6K Pendent Concealed Quick Response, Extended Coverage

IMPORTANT

Refer to Technical Data Sheet TFP2300 for warnings pertaining to regulatory and health information.

Always refer to Technical Data Sheet TFP700 for the "INSTALLER WARNING" that provides cautions with respect to handling and installation of sprinkler systems and components. Improper handling and installation can permanently damage a sprinkler system or its components and cause the sprinkler to fail to operate in a fire situation or cause it to operate prematurely.

Scan the QR code or enter the URL in a web browser to access the most up-to-date electronic version of this document. Data rates may apply.



docs.jci.com/tycofire/TFP518

General Description

TYCO Series DS-ECC Dry Type Sprinklers, 5.6K Pendent Concealed, Quick Response (3 mm Bulb), Extended Coverage (TY3539), are decorative bulb-type sprinklers featuring a flat cover plate designed to conceal the sprinkler. This type of sprinkler is typically used to provide a sprinkler drop from an unheated attic into an area where aesthetics is a concern, such as nursing homes, restaurants, and schools.

They are intended for use in automatic sprinkler systems designed in accordance with standard installation rules, for example, NFPA 13. The fast response thermal sensitivity rating of Series DS-ECC Dry Type Sprinklers (TY3539) provides for a quick response extended coverage (QREC) rating up to an 18 ft (5,5 m) x 18 ft (5,5 m) coverage area.

Each unit includes a cover plate assembly that conceals the sprinkler operating components above the ceiling. The separable two-piece design of the cover plate and support cup assemblies allows installation of the sprinklers and pressure testing of the fire protection system prior to installation of a suspended ceiling or application of the finish coating to a fixed ceiling. They also permit removal of suspended ceiling panels for access to building service equipment without having to first shut down the fire protection system and remove sprinklers. Also, the separable two-piece design of the sprinkler provides for 1/2 in. (12,7 mm) of vertical adjustment.

Each Series DS-ECC Dry Type Sprinkler is shipped with a disposable protective cap. The protective cap is temporarily removed for installation, and then it can be replaced to help protect the sprinkler while the ceiling is being installed or finished. The tip of the protective cap can also be used to mark the center of the ceiling hole into plaster board and ceiling tiles by gently



pushing the ceiling product against the protective cap. When the ceiling installation is complete, the protective cap is removed and the cover plate assembly installed.

NOTICE

Series DS-ECC Dry Type Pendent Concealed Sprinklers described herein must be installed and maintained in compliance with this document and the applicable standards of the NATIONAL FIRE PROTECTION ASSOCIATION (NFPA), in addition to the standards of any authorities having jurisdiction. Failure to do so may impair the performance of these devices.

The owner is responsible for maintaining their fire protection system and devices in proper operating condition. Contact the installing contractor or product manufacturer with any questions.

Series DS-ECC Dry Type Pendent Concealed Sprinklers must only be installed in fittings that meet the requirements of the Design Criteria section.

Sprinkler Identification Number (SIN)

TY3539

Technical Data

Approvals

UL and C-UL Listed
 NYC Approved under MEA 352-01-E-2

See the Design Criteria section

Maximum Working Pressure

175 psi (12,1 bar)

Inlet Thread Connections

1 in. NPT (Standard Order)
 ISO 7-R1

Discharge Coefficient

$K=5.6 \text{ gpm/psi}^{1/2}$
 $(80,6 \text{ Lpm/bar}^{1/2})$

Temperature Ratings

155°F (68°C) Sprinkler with
 139°F (59°C) Cover Plate

200°F (93°C) Sprinkler with
 165°F (74°C) Cover Plate

Adjustment

1/2 in. (12,7 mm)

Finishes

See the Ordering Procedure section

Physical Characteristics

Inlet	Copper
Plug	Copper
Yoke	Stainless Steel
Casing	Galvanized Carbon Steel
Insert	Bronze
Bulb Seat	Stainless Steel
Bulb	Glass
Deflector	Bronze
Frame	Bronze
Guide Tube	Stainless Steel
Water Tube	Stainless Steel
Spring	Stainless Steel Gasketed Spring Plate Seal
Support Cup	Beryllium Nickel w/TEFLON
Support Cup	Chrome Plated Steel
Guide Pins	Stainless Steel
Compression Screw	Brass
Cover Plate	Brass
Retainer	Brass
Ejection Spring	Stainless Steel

Operation

When TYCO Series DS-ECC Dry Type Sprinklers, 5.6K Pendent Concealed, Quick Response, Extended Coverage (TY3539) are in service, water is prevented from entering the assembly by the plug and gasketed spring plate seal as shown in Figure 1 in the inlet of the sprinkler.

When exposed to heat from a fire, the cover plate, which is normally soldered to the retainer at three points, falls away to expose the sprinkler assembly. At this point the deflector supported by the guide pins drops down to its operational position.

The glass bulb contains a fluid that expands when exposed to heat. When the rated temperature is reached, the fluid expands sufficiently to shatter

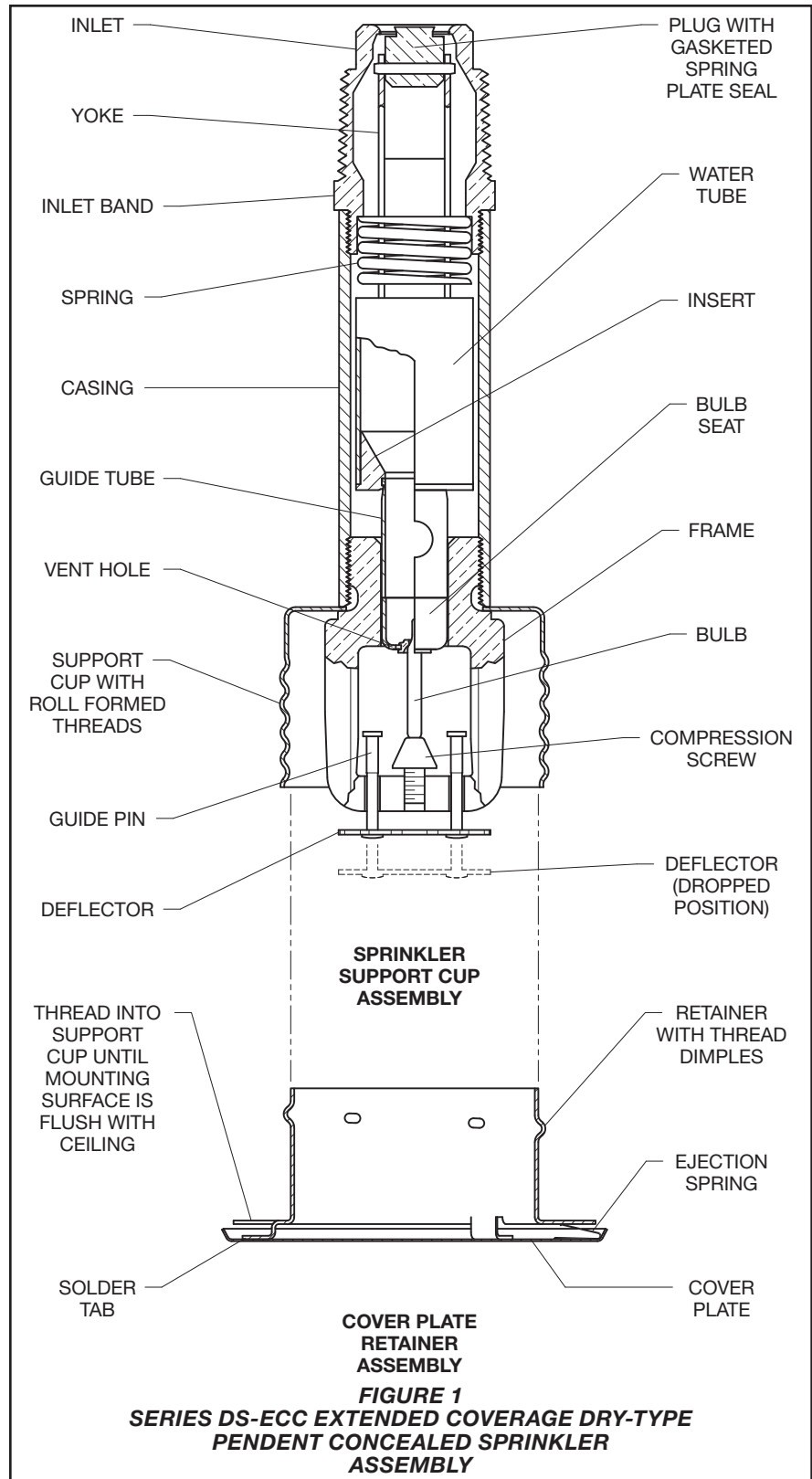

the glass bulb, and the bulb seat is released. The compressed spring is then able to expand and push the water tube as well as the guide tube outward. This action simultaneously pulls inward

on the yoke, withdrawing the plug and gasketed spring plate seal from the inlet allowing the sprinkler to activate and flow water.

Response Rating	Spacing	Minimum Flow/Pressure
Quick	16 ft x 16 ft (4,9 m x 4,9 m)	26.0 GPM/21.6 psi (98,4 LPM/1,49 bar)
Quick	18 ft x 18 ft (5,5 m x 5,5 m)	33.0 GPM/34,7 psi (124,9 LPM/2,39 bar)

TABLE A
SERIES DS-ECC EXTENDED COVERAGE DRY-TYPE PENDENT
CONCEALED SPRINKLERS (TY3539) 155°F (68°C) AND 200°F (93°C)
HYDRAULIC DESIGN CRITERIA

Design Criteria

TYCO Series DS-ECC Dry Type Sprinklers, 5.6K Pendent Concealed, Quick Response, Extended Coverage (TY3539) are UL and C-UL Listed for use in light hazard occupancies, using the design criteria in Table A, in addition to the requirements specified in the current NFPA 13 for extended coverage pendent sprinklers.

Series DS-ECC Dry-Type Sprinklers are only listed when installed with Series RFII Concealed Cover Plates having a factory applied painted or metallic finish.

NOTICE

Series DS-ECC Sprinklers must not be used in applications where the air pressure above the ceiling is greater than that below. Down drafts through the support cup could delay sprinkler operation in a fire situation.

Sprinkler Fittings

Install 1 in. NPT Series DS-ECC Dry-Type Sprinklers are to be installed in the 1 in. NPT outlet or run of the following fittings:

- Malleable or ductile iron threaded tee fittings that meet the dimensional requirements of ANSI B16.3 (Class 150)
- Cast iron threaded tee fittings that meet the dimensional requirements of ANSI B16.4 (Class 125)

Do not install Series DS-ECC Dry-Type Sprinklers into elbow fittings. The inlet of the sprinkler can contact the interior of the elbow.

The unused outlet of the threaded tee is plugged as shown in Figures 6.

You can also install Series DS-ECC Dry-Type Sprinklers in the 1 in. NPT outlet of a GRINNELL Figure 730 Mechanical Tee. However, the use of the Figure 730 Tee for this arrangement is limited to wet pipe systems.

The configuration shown in Figure 5 is only applicable for wet pipe systems where the sprinkler fitting and water-filled pipe above the sprinkler fitting

are not subject to freezing and where the length of the dry-type sprinkler has the minimum exposure length depicted in Figure 7. See the Exposure Length section.

For wet pipe system installations of 1 in. NPT Series DS-ECC Dry-Type Sprinklers connected to CPVC piping, use only the following TYCO CPVC fittings:

- 1 in. x 1 in. NPT female adapter (P/N 80145)
- 1 in. x 1 in. x 1 in. NPT sprinkler head adapter tee (P/N 80249)

For dry pipe system installations, use only the side outlet of maximum 2 1/2 in. reducing tee when locating Series DS-ECC Dry-Type Sprinklers directly below the branch line. Otherwise, use the configuration shown in Figure 4 to assure complete water drainage from above Series DS-ECC Dry-Type Sprinklers and the branch line. Failure to do so may result in pipe freezing and water damage.

NOTICE

Do not install Series DS-ECC Dry-Type Sprinklers into any other type fitting. Failure to use the appropriate fitting may result in one of the following:

- *Failure of the sprinkler to operate properly due to formation of ice over the Inlet Plug or binding of the Inlet Plug*
- *Insufficient engagement of the Inlet pipe-threads with consequent leakage*

Drainage

In accordance with the minimum requirements of the NATIONAL FIRE PROTECTION ASSOCIATION for dry pipe sprinkler systems, branch, cross, and feed-main piping connected to dry sprinklers and subject to freezing temperatures must be pitched for proper drainage.

Exposure Length

When using dry sprinklers in wet pipe sprinkler systems to protect areas subject to freezing temperatures, use Table B to determine a sprinkler's appropriate exposed barrel length to prevent water from freezing in the connecting pipes due to conduction. The

Ambient Temperature Exposed to Discharge End of Sprinkler	Temperatures for Heated Area ^a		
	40°F (4°C)	50°F (10°C)	60°F (16°C)
	Minimum Exposed Barrel Length ^b , in. (mm)		
40°F (4°C)	0	0	0
30°F (-1°C)	0	0	0
20°F (-7°C)	4 (100)	0	0
10°F (-12°C)	8 (200)	1 (25)	0
0°F (-18°C)	12 (305)	3 (75)	0
-10°F (-23°C)	14 (355)	4 (100)	1 (25)
-20°F (-29°C)	14 (355)	6 (150)	3 (75)
-30°F (-34°C)	16 (405)	8 (200)	4 (100)
-40°F (-40°C)	18 (455)	8 (200)	4 (100)
-50°F (-46°C)	20 (510)	10 (255)	6 (150)
-60°F (-51°C)	20 (510)	10 (255)	6 (150)

Notes:
a. For protected area temperatures that occur between values listed above, use the next cooler temperature.
b. These lengths are inclusive of wind velocities up to 30 mph (18,6 kph).

TABLE B
EXPOSED SPRINKLER BARRELS
IN WET PIPE SYSTEMS
MINIMUM RECOMMENDED LENGTHS

exposed barrel length measurement must be taken from the face of the sprinkler fitting to the surface of the structure or insulation that is exposed to the heated area. For an example, see Figure 5.

For protected area temperatures between those given above, the minimum recommended length from the face of the fitting to the outside of the protected area may be determined by interpolating between the indicated values.

Do not attempt to add additional insulation around the barrel in the heated area as a method to minimize condensation. This will reduce the calculated "Exposure Length".

Clearance Space

In accordance with NFPA 13, where dry sprinklers are connected to wet pipe sprinkler systems protecting insulated freezer structures, the clearance space around the sprinkler barrel of dry-type sprinklers must be sealed. Due to tem-

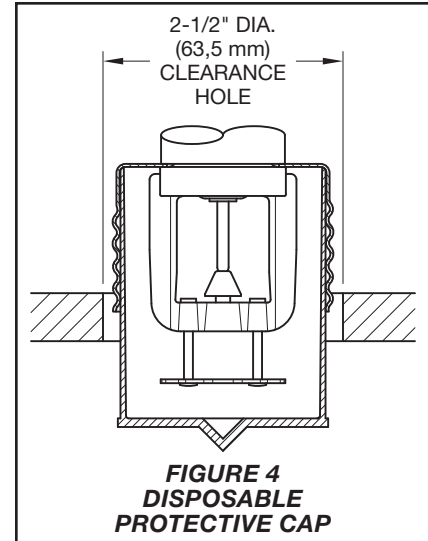
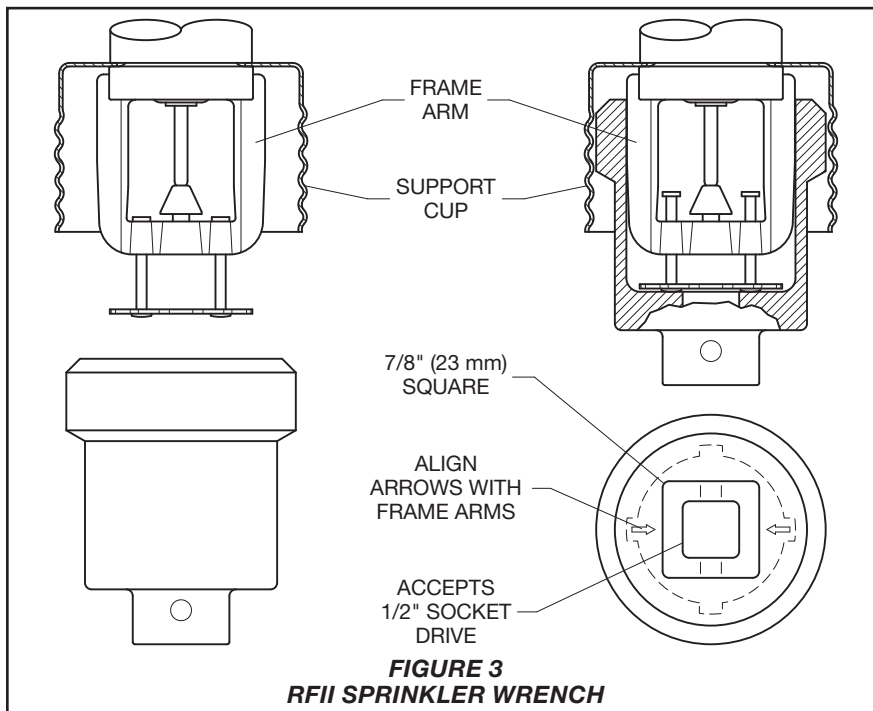
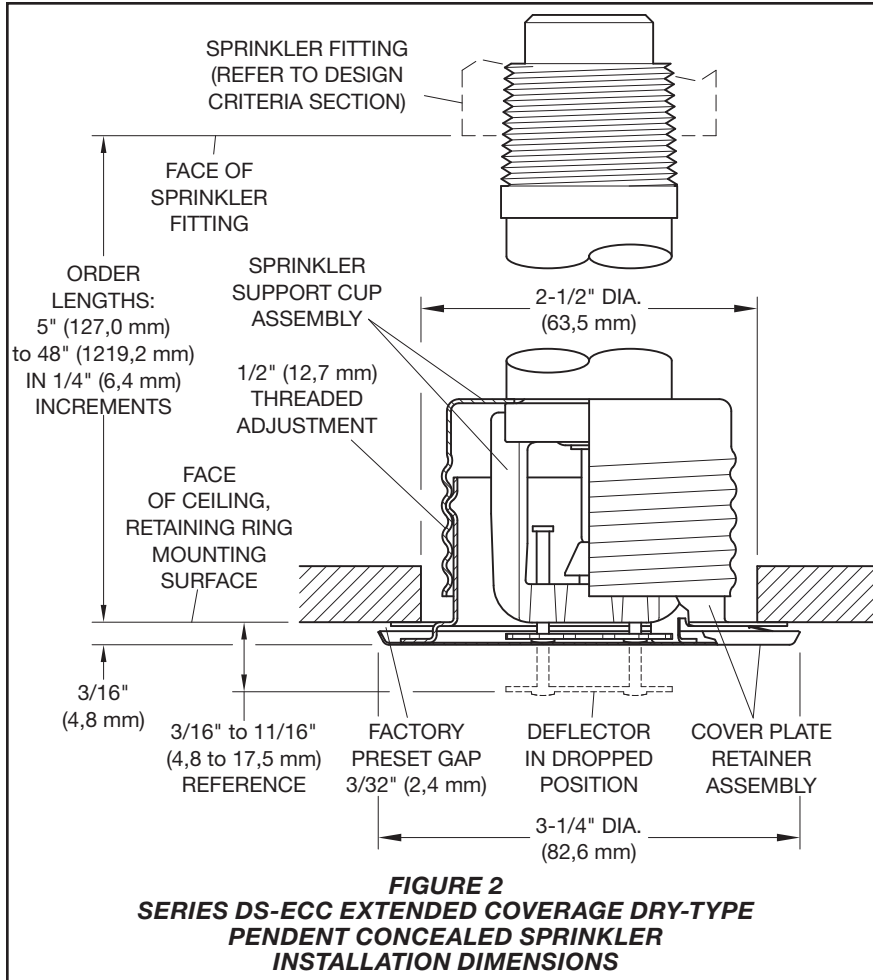

perature differences between two areas, the potential for the formation of condensation in the sprinkler and subsequent ice build-up is increased. If this condensation is not controlled, ice build-up can occur that might damage the dry-type sprinkler and/or prevent proper operation in a fire situation.

Use of the Model DSB-2 Dry Sprinkler Boot, described in Technical Data Sheet TFP591 and shown in Figure 6, can provide the recommended seal.

NOTICE

For applications where a bore greater than 1 3/4 in. in diameter has been cut through the entire height of an insulated freezer ceiling creating a cavity above the sprinkler support cup (see Figure 8), the cavity must not be filled.

Installation

TYCO Series DS-ECC Dry Type Sprinklers, 5.6K Pendent Concealed, Quick Response, Extended Coverage (TY3539) must be installed in accordance with this section.

General Instructions

Series DS-ECC Dry-Type Sprinklers must only be installed in fittings that meet the requirements of the Design Criteria section. See the Design Criteria section for other important requirements regarding piping design and sealing of the clearance space around the Sprinkler Casing.

Do not install any bulb type sprinkler if the bulb is cracked or there is a loss of liquid from the bulb. With the sprinkler held horizontally, a small air bubble should be present. The diameter of the air bubble is approximately 1/16 in. (1,6 mm).

A leak-tight 1 in. NPT sprinkler joint should be obtained with a minimum-to-

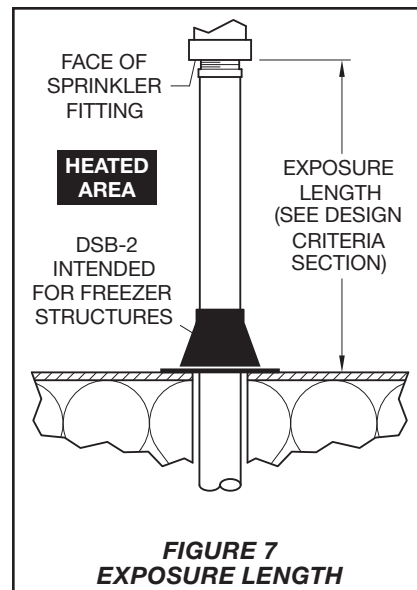
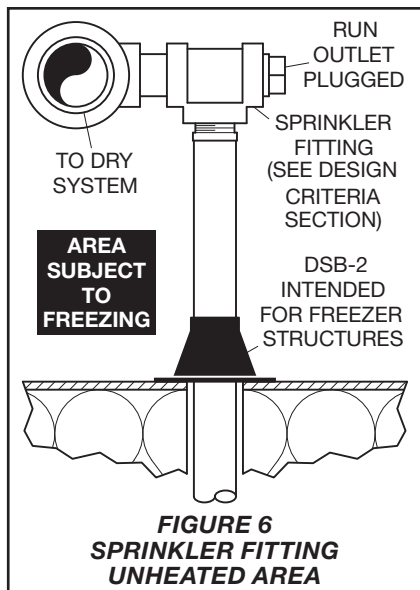
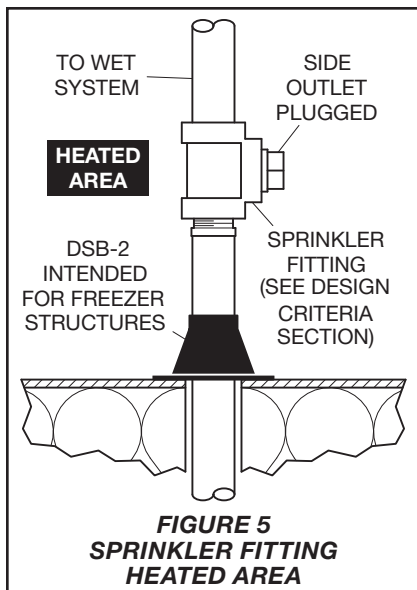

maximum torque of 20 ft-lb to 30 ft-lb (26,8 N·m to 40,2 N·m). Higher levels of torque may distort the sprinkler Inlet with consequent leakage or impairment of the sprinkler.

Do not attempt to compensate for insufficient adjustment in the sprinkler assembly by under or over-tightening the sprinkler/support cup assembly. Re-adjust the position of the sprinkler fitting to suit.

Step 1. Install pendent sprinklers only in the pendent position and with the centerline of the sprinkler perpendicular to the mounting surface.

Step 2. With a non-hardening pipe-thread sealant such as TEFLON applied to the inlet threads, hand-tighten the sprinkler into the sprinkler fitting.

Step 3. Wrench-tighten the sprinkler using either of the following tools:

- Pipe wrench on the inlet band or the casing shown in Figure 1.
- RFII Sprinkler Wrench as shown in Figure 3 on the wrench flat.

Note: If sprinkler removal becomes necessary, remove the sprinkler using the same wrenching method noted above. Sprinkler removal is easier when a non-hardening sealant was used and torque guidelines were followed. After removal, inspect the sprinkler for damage.

When using the RFII Sprinkler Wrench, temporarily remove the protective cap. Replace the protective Cap shown in Figure 4 by pushing it upwards until it bottoms out against the support cup. The protective cap helps prevent damage to the deflector and arms during ceiling installation and/or during application of the finish coating of the ceiling. It may also be used to locate the center of the clearance hole by

gently pushing the ceiling material up against the center point of the protective cap.

NOTICE

As long as the protective cap remains in place, the system is considered to be "Out of Service".

Step 4. After the ceiling has been completed with the 2 1/2 in. (63,5 mm) diameter hole and in preparation for installing the cover plate assembly, remove and discard the protective cap. Verify that the deflector moves up and down freely. If the sprinkler has been damaged and the deflector does not move up and down freely, replace the entire sprinkler assembly. Do not attempt to modify or repair a damaged sprinkler.

Step 5. Screw on the cover plate/retainer assembly until the retainer (see Figure 2) contacts the ceiling. Do not continue to screw on the cover plate/retainer assembly so that it lifts a ceiling panel out of its normal position. If the cover plate/retainer assembly cannot be engaged with the support cup or the cover plate/retainer assembly cannot be engaged sufficiently to contact the ceiling, reposition the sprinkler fitting.

Care and Maintenance

TYCO Series DS-ECC Dry Type Sprinklers, 5.6K Pendent Concealed, Quick Response, Extended Coverage (TY3539) must be maintained and serviced in accordance with this section.

Before closing a fire protection system main control valve for maintenance

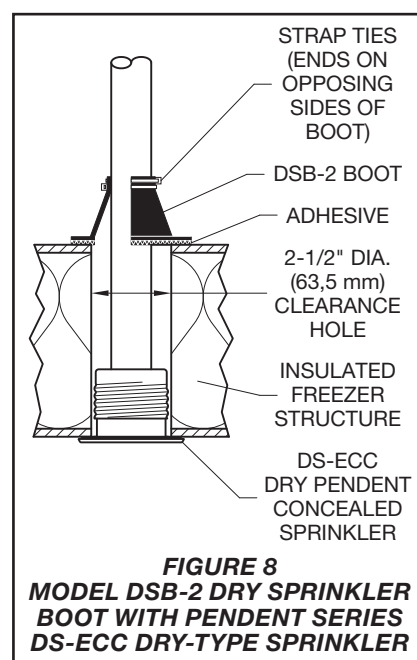

work on the fire protection system that it controls, permission to shut down the affected fire protection systems must be obtained from the proper authorities and notify all personnel who may be affected by this action.

Absence of the outer piece of an escutcheon, which is used to cover a clearance hole, may delay the time to sprinkler operation in a fire situation.

A vent hole is provided in the bulb seat (see Figure 1) to indicate if the dry sprinkler is remaining dry. Evidence of leakage from the vent hole indicates potential leakage past the Inlet seal and the need to remove the sprinkler to determine the cause of leakage; for example, an improper installation or an ice plug. Close the fire protec-

P/N* 60 – 45X – 1 – XXX

		SIN						
45	DS-ECC (3 mm Bulb)	TY3539						

Temperature Rating		Order Length**		Order Length**	
1	155°F (68°C)	055	5.50 in.	187	18.75 in.
3	200°F (93°C)	082	8.25 in.	372	37.25 in.
		180	18.00 in.	480	48.00 in.

NOTES
* Use Prefix "I" for ISO 7-R1 Connection (for example, I-60-451-1-180).
** Dry-Type Sprinklers are furnished based upon "Order Length" as measured per Figure 2, as applicable, for each individual sprinkler where it is to be installed. After the measurement is taken, round it to the nearest 1/4 in. increment.

TABLE C
SERIES DS-ECC EXTENDED COVERAGE
DRY-TYPE CONCEALED PENDENT SPRINKLER
PART NUMBER SELECTION

tion system control valve and drain the system before removing the sprinkler.

The owner must assure that the sprinklers are not used for hanging any objects and that the sprinklers are only cleaned by means of gently dusting with a feather duster; otherwise, non-operation in the event of a fire or inadvertent operation may result.

Sprinklers which are found to be leaking or exhibiting visible signs of corrosion must be replaced.

Automatic sprinklers must never be painted, plated, coated, or otherwise altered after leaving the factory. Modified sprinklers must be replaced. Sprinklers that have been exposed to corrosive products of combustion, but have not operated, should be replaced if they cannot be completely cleaned by wiping the sprinkler with a cloth or by brushing it with a soft bristle brush.

Care must be exercised to avoid damage to the sprinklers - before, during, and after installation. Sprinklers damaged by dropping, striking, wrench twist/slippage, or the like, must be replaced. Also, replace any sprinkler that has a cracked bulb or that has lost liquid from its bulb. See the Installation section for additional information.

The owner is responsible for the inspection, testing, and maintenance of their fire protection system and devices in compliance with this document, as well as with the applicable standards of the NATIONAL FIRE PROTECTION ASSOCIATION, such as NFPA 25, in addition to the standards of any other authorities having jurisdiction. Contact the installing contractor or product manufacturer with any questions.

Automatic sprinkler systems are recommended to be inspected, tested, and maintained by a qualified Inspection Service in accordance with local requirements and/or national codes.

Limited Warranty

For warranty terms and conditions, visit www.tyco-fire.com.

Ordering Procedure

Contact your local distributor for availability. When placing an order, indicate the full product name, including description and Part Number (P/N).

Dry Type Sprinkler Assemblies

Specify: Series DS-ECC (TY3539) 5.6 K-factor Pendent Concealed Quick Response, Extended Coverage, (specify) temperature rating, (specify) length, and Inlet Connection. See Table C for part numbers.

Order Length

Dry Type Sprinklers are furnished based upon Order Length as measured from the face of the ceiling to the face of the sprinkler fitting, see Figure 2. After the measurement is taken, round it to the nearest 1/4 in. increment.

Inlet Connections

1 in. NPT or ISO 7-R1

Separately Ordered Cover Plate

Specify: Series RFI Concealed Cover Plate with (specify) temperature rating, (specify) finish, P/N (specify):

139°F (59°C) Cover Plate

for use with 155°F (68°C) Sprinkler

Grey White (RAL9002)	56-792-0-135
Brass	56-792-1-135
Pure White (RAL9010)*	56-792-3-135
Signal White (RAL9003)	56-792-4-135
Jet Black (RAL9005)	56-792-6-135
Terra Brown (RAL8028)	56-792-7-135
Chrome	56-792-9-135
Custom	56-792-X-135

165°F (74°C) Cover Plate

for use with 200°F (93°C) Sprinkler

Grey White (RAL9002)	56-792-0-165
Brass	56-792-1-165
Pure White (RAL9010)*	56-792-3-165
Signal White (RAL9003)	56-792-4-165
Jet Black (RAL9005)	56-792-6-165
Terra Brown (RAL8028)	56-792-7-165
Chrome	56-792-9-165
Custom	56-792-X-165

*Eastern Hemisphere Sales Only

Sprinkler Wrench

Specify RFI Sprinkler Wrench, P/N 56-000-1-075

Sprinkler Boot

Specify: Model DSB-2 Dry Sprinkler Boot, P/N 63-000-0-002

This part number includes one boot, two strap ties, and 1/3 oz. of adhesive (a sufficient quantity for installing one boot), refer to Technical Data Sheet TFP591 for complete information.



TFP518 Change History Appendix

ISSUE DATE	NOTES
08-22	Page 1, updated QR code and URL; Page 6, changed corporate address and telephone number to 1467 Elmwood Avenue, Cranston, RI 02910 Telephone +1-401-781-8220, formerly 1400 Pennbrook Parkway, Lansdale, PA 19446 Telephone +1-215-362-0700.
05-22	Page 1, added QR code and URL to allow convenient access to electronic version from printed document; Page 6, Ordering Procedure, added Terra Brown (RAL8028) cover plate options, 135°F P/N 56-792-7-135 and 165°F P/N 56-792-7-165; Shortened document to 6 pages, formerly 8.
11-19	Removed consulting Technical Services Department statement from Sprinkler Fittings subsection Notice.
02-19	Corrected spacing requirements in Table A to feet, formerly inches.
08-18	Updated Tyco® branding and document format; Added Johnson Controls copyright; Added disclaimer stating specifications and information subject to change without notice; Added reference to Regulatory and Health Warning Technical Data Sheet TFP2300.
05-17	Updated limited warranty information.
06-13	Updated and standardized RAL color finishes.
08-12	Added notice not to fill space between sprinkler barrel and clearance holes greater than 1-3/4 in. dia. bored through insulated freezer ceilings.
05-11	Clarified NYC Approved; Updated minimum order and exposed barrel lengths; Improved Design Criteria section; Updated patent information.
05-08	Changed Cover Plate Assembly Temperature Rating to 139°F (58°C), formerly shown as 135°F (57°C); Updated Cover Plate Assembly standard order finishes.
12-07	Added Model DSB-2 Dry Sprinkler Boot; Added NFPA 13 requirements for use of DSB-2; Added illustrations providing guidance on alternative piping connections to dry type sprinklers for freeze protection or system drainage; Added Natural Brass sprinkler with Brass plate escutcheon finish option.
04-04	Added reference to Installer Warning data sheet TFP700; Corrected minimum order length to 5 in (127,0 mm), formerly 4-3/4 in. (120,6 mm); Added guidance on use of compatible CPVC fittings.
12-03	Technical data sheet TFP518 describes Series DS-ECC, 5.6 K-factor, Extended Coverage, Light Hazard, Quick Response, Dry Pendent Concealed Sprinklers.