

## **Model ELOC — 11.2 K-factor Extra Large Orifice Concealed Pendent Sprinklers Quick and Standard Response, Extended Coverage**

### **IMPORTANT**

Refer to Technical Data Sheet TFP2300 for warnings pertaining to regulatory and health information.

Always refer to Technical Data Sheet TFP700 for the "INSTALLER WARNING" that provides cautions with respect to handling and installation of sprinkler systems and components. Improper handling and installation can permanently damage a sprinkler system or its components and cause the sprinkler to fail to operate in a fire situation or cause it to operate prematurely.

Scan the QR code or enter the URL in a web browser to access the most up-to-date electronic version of this document. Data rates may apply.



[docs.jci.com/tycofire/TFP250](http://docs.jci.com/tycofire/TFP250)

### **General Description**

The TYCO Model ELOC, 11.2 K-factor, Extended Coverage, Light Hazard, Extra Large Orifice Concealed (ELOC) Pendent Sprinklers are decorative, fast response solder type sprinklers featuring a flat cover plate designed to conceal the sprinkler. When limited water pressure is available, the sprinkler is the best choice for architecturally sensitive areas such as hotel lobbies, office buildings, churches, and restaurants.

They are intended for use in automatic sprinkler systems designed in accordance with standard installation rules such as NFPA 13. The fast response thermal sensitivity rating of the sprinkler provides for a quick response extended coverage (QREC) rating up to an 18 ft x 18 ft (5.5 m x 5.5 m) coverage area.

Each unit includes a cover plate assembly that conceals the sprinkler operating components above the ceiling. The separable two-piece design of the cover plate and support cup assemblies allows installation of the sprinklers and pressure testing of the fire protection system prior to installation of a suspended ceiling or application of the finish coating to a fixed ceiling. They also permit removal of suspended ceiling panels for access to building service equipment without having to first shut down the fire protection system and remove sprinklers.

Also, the separable two-piece design of the sprinkler provides for 3/4 in. (19,1 mm) of vertical adjustment to provide a measure of flexibility with regard to which the length of fixed pipe drops to the sprinklers must be cut.

The sprinklers are shipped with a disposable protective cap. The protective cap is temporarily removed for installation, and it can be replaced to help protect the sprinkler while the ceiling is being installed or finished. The tip of the protective cap can also be used to mark the center of the ceiling hole into plaster board, ceiling tiles, or relevant surfaces by gently pushing the ceiling product against the protective cap. When the ceiling installation is complete the protective cap is removed and the cover plate assembly installed.

As an option, the Model ELOC Pendent Sprinklers may be fitted with a silicone air and dust seal as shown in Figure 4. The air and dust seal is intended for sensitive areas where it is desirable to stop air and dust travel through the cover plate from the area above the ceiling.



### **NOTICE**

The Model ELOC Pendent Sprinklers described herein must be installed and maintained in compliance with this document and with the applicable standards of the National Fire Protection Association, in addition to the standards of any authorities having jurisdiction. Failure to do so may impair the performance of these devices.

The owner is responsible for maintaining their fire protection system and devices in proper operating condition. Contact the installing contractor or product manufacturer with any questions.

### **Sprinkler Identification Number**

TY5522

Note: TY5522 is a redesignation for C5522.

# Technical Data

## Approvals

UL and C-UL Listed  
NYC Approved under MEA 177-03-E

**Note:** The listings apply only to the service conditions indicated in the Design Criteria section.

## Approvals for Air & Dust Seal

UL and C-UL Listed

For complete approval information, see Table A.

## Maximum Working Pressure

175 psi (12,1 bar)

## Discharge Coefficient

$K = 11.2 \text{ gpm/psi}^{1/2}$  (161,3 Lpm/bar<sup>1/2</sup>)

## Temperature Rating

160°F (71°C) Sprinkler/139°F (59°C) Plate  
212°F (100°C) Sprinkler/165°F (74°C) Plate

## Adjustment

3/4 in. (19,1 mm)

## Finishes

See Ordering Procedure section

## Physical Characteristics

Body .....Brass  
Cap .....Bronze  
Saddle .....Brass  
Sealing Assembly . . .Beryllium Nickel w/TEFLON  
Solder Link Halves ..... Nickel  
Lever ..... Bronze  
Compression Screw .....Brass  
Deflector ..... Bronze/Brass  
Guide Pin Housing ..... Bronze  
Guide Pins ..... Stainless Steel  
Support Cup .....Plated Steel  
Cover Plate .....Brass  
Retainer .....Brass  
Cover Plate Ejection Spring . . . . Stainless Steel

# Operation

When exposed to heat from a fire, the cover plate that is normally soldered to the retainer at three points, falls away to expose the sprinkler assembly. At this point the deflector supported by the guide pins drops down to its operational position.

When the rated temperature of the solder link element is reached, the link element separates, allowing the sprinkler to activate and flow water.

# Design Criteria

The Model ELOC Pendent Sprinklers are UL and C-UL Listed for use in light hazard occupancies, using the design criteria in Table A, in addition to the requirements specified in the current NFPA 13 for extended coverage pendent sprinklers.

The ELOC pendent sprinklers are only listed and approved with the ELOC concealed cover plates having a factory applied finish.

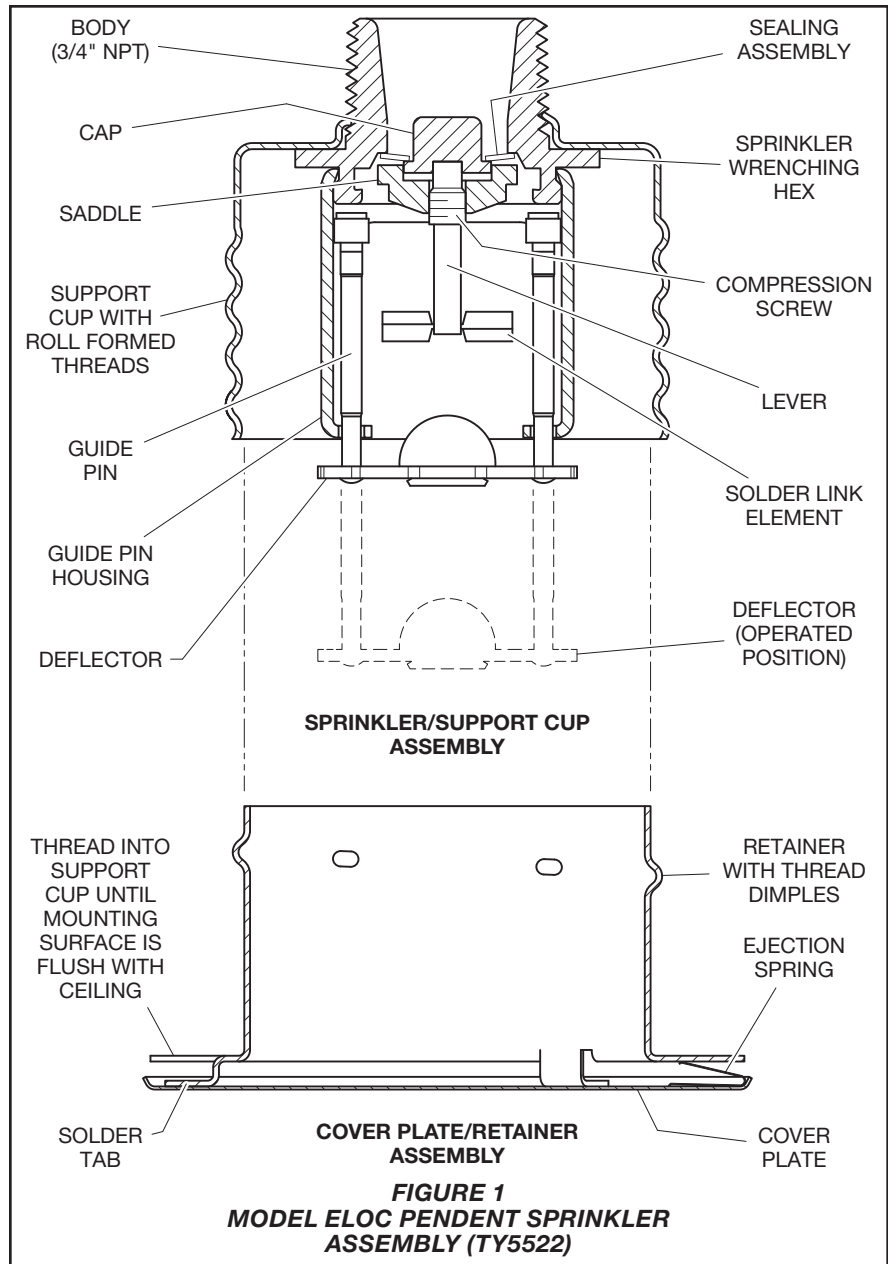

RESPONSE RATING	SPACING	MINIMUM FLOW/PRESSURE
QUICK <sup>1</sup>	16 ft x 16 ft (4,9 m x 4,9 m)	30.0 gpm/7.2 psi (113,6 Lpm/0,50 bar)
QUICK <sup>1</sup>	18 ft x 18 ft (5,5 m x 5,5 m)	33.0 gpm/8.7 psi (124,9 Lpm/0,60 bar)
STANDARD	20 ft x 20 ft (6,1 m x 6,1 m)	40.0 gpm/12.8 psi (151,4 Lpm/0,88 bar)

**NOTES**  
1. The 16 ft x 16 ft (4,9 m x 4,9 m) and 18 ft x 18 ft (5,5 m x 5,5 m) coverage areas are rated standard response when the air and dust Seal as shown in Figure 4 is utilized.

**TABLE A**  
**MODEL ELOC 160°F (71°C) AND 212°F (100°C)**  
**PENDENT SPRINKLER (TY5522)**  
**HYDRAULIC DESIGN CRITERIA**

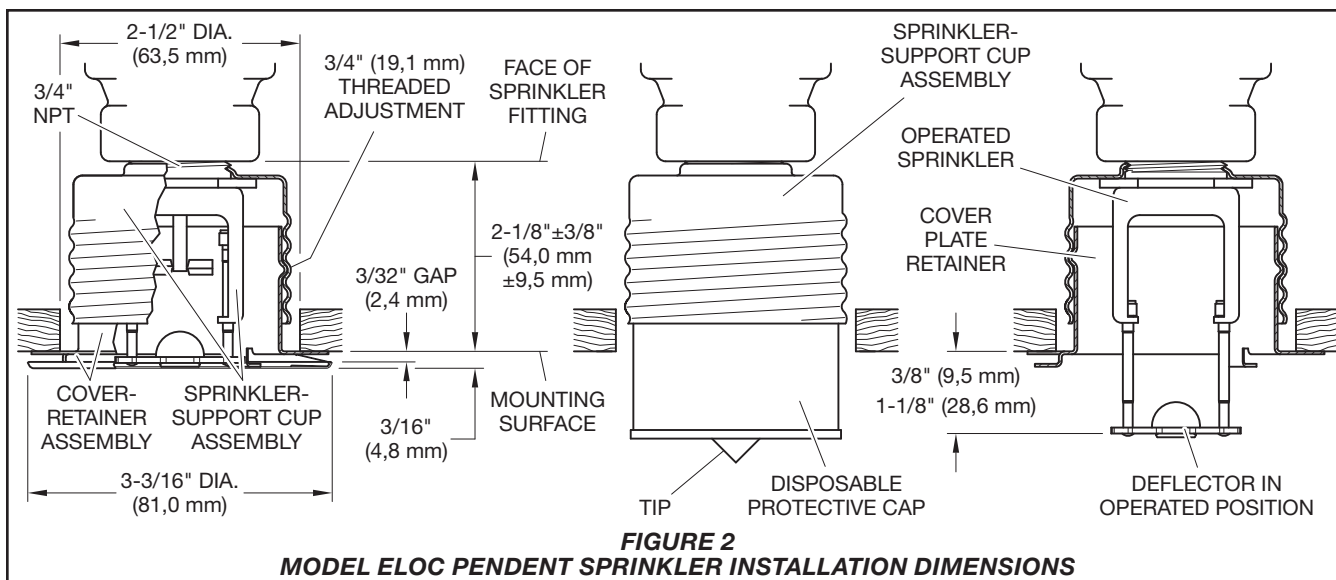

The sprinkler must not be used in applications where the air pressure above the ceiling is greater than that below. Down drafts through the support cup could delay sprinkler operation in a fire situation.

## Installation

The TYCO Model ELOC Pendent Sprinkler must be installed in accordance with this section.

### General Instructions

A leak tight 3/4 in. NPT sprinkler joint should be obtained with a minimum to maximum torque of 10 ft-lb to 20 ft-lb (13,4 N·m to 26,8 N·m). Higher levels of torque may distort the sprinkler inlet with consequent leakage or impairment of the sprinkler.

Do not attempt to compensate for insufficient adjustment in the sprinkler assembly by under- or over-tightening the sprinkler/support cup assembly. Readjust the position of the sprinkler fitting to suit.

**Step 1.** The sprinkler must only be installed in the pendent position and with the centerline of the sprinkler perpendicular to the mounting surface.

**Step 2.** Remove the protective cap.

**Step 3.** With pipe thread sealant applied to the pipe threads, hand tighten the sprinkler into the sprinkler fitting.

**Step 4.** Wrench tighten the sprinkler using only the W-Type 18 Sprinkler Wrench shown in Figure 3. Apply the wrench to the sprinkler as shown in Figure 3.

**Step 5.** Replace the protective cap as shown in Figure 2 by pushing it

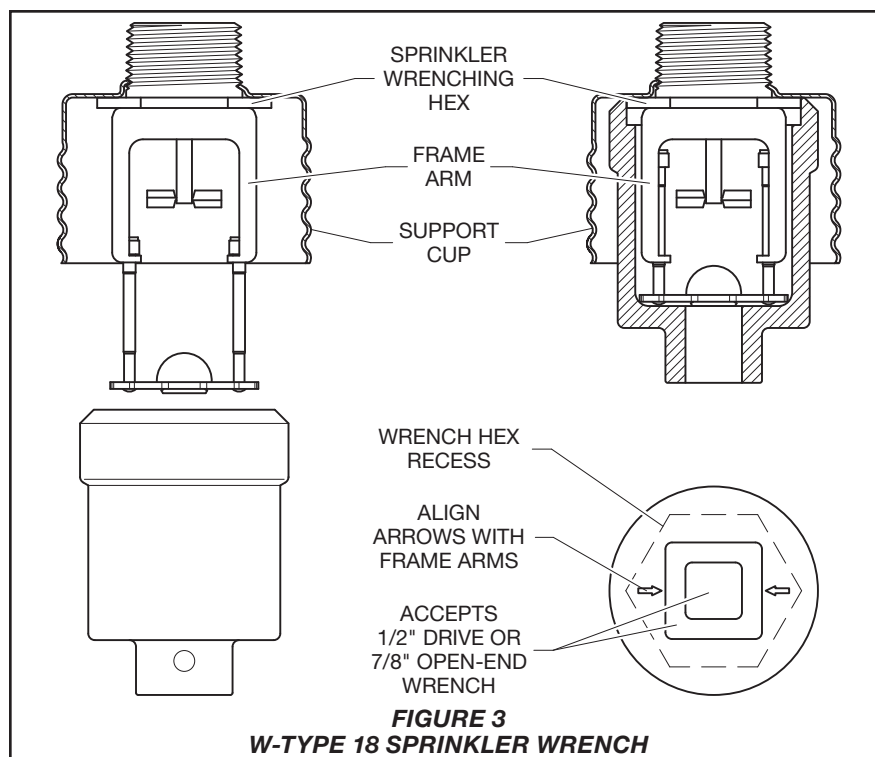

upwards until it bottoms out against the support cup. The protective cap helps prevent damage to the deflector and arms during ceiling installation and/or during application of the finish coating of the ceiling. It may also be used to locate the center of the clearance hole by gently pushing the ceiling material against the center point of the protective cap.

### NOTICE

*As long as the protective cap remains in place, the system is considered to be "Out of Service".*

**Step 6.** When the ceiling is completed with the 2-1/2 in. (63,5 mm) diameter clearance hole and in preparation for installing the cover plate assembly, remove and discard the protective cap, and verify that the deflector moves up and down freely. If the sprinkler has been damaged and the deflector does not move up and down freely, replace the entire sprinkler assembly. Do not attempt to modify or repair a damaged sprinkler.

**Step 7.** When installing an air and dust seal, refer to Figure 4, otherwise proceed to Step 8. To attach the air and dust seal, verify the angle of the outside

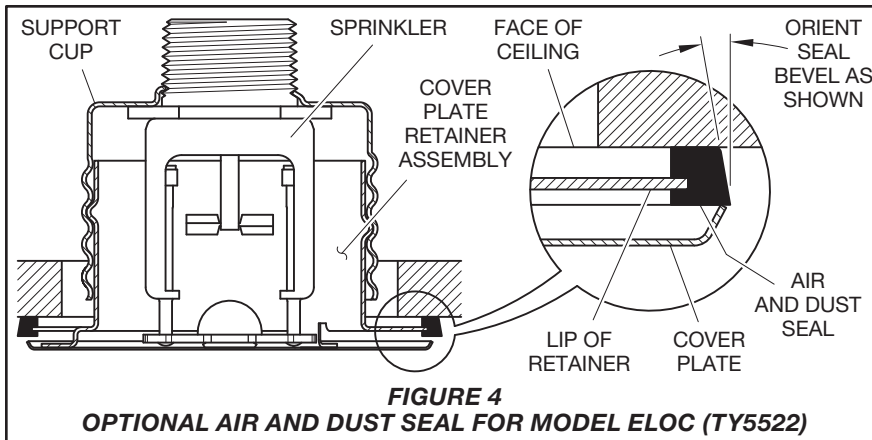

**FIGURE 4**  
**OPTIONAL AIR AND DUST SEAL FOR MODEL ELOC (TY5522)**

edge of the seal is oriented according to Figure 4. Start the edge of the retainer in the grooved slot of the air and dust seal and continue around the retainer until the entire air and dust seal is engaged.

**Step 8.** Screw on the cover plate/retainer assembly until the retainer (see Figure 2) or air and dust seal (see Figure 4) contacts with the ceiling. Do not continue to screw on the cover plate/retainer assembly such that it lifts a ceiling panel out of its normal position. If the cover plate/retainer assembly cannot be engaged with the support cup or the cover plate/retainer assembly cannot be engaged sufficiently to contact the ceiling, the sprinkler fitting must be repositioned.

## Care and Maintenance

The TYCO Model ELOC Pendent Sprinkler must be maintained and serviced in accordance with this section.

Before closing a fire protection system main control valve for maintenance work on the fire protection system that it controls, permission to shut down the affected fire protection system must be obtained from the proper authorities and all personnel who may be affected by this action must be notified.

Absence of the cover plate assembly may delay sprinkler operation in a fire situation. When properly installed, there is a nominal 3/32 in. (2,4 mm) air gap between the lip of the cover plate and the ceiling, as shown in Figure 2. This air gap is necessary for proper operation of the sprinkler. If the ceiling is to be repainted after the installation of the sprinkler, care must be exercised to ensure that the new paint does not seal off any of the air gap.

Factory painted cover plates must not be repainted. They should be replaced, if necessary, by factory painted units. Non-factory applied paint may adversely delay or prevent sprinkler operation in the event of a fire.

Do not pull the cover plate relative to the enclosure. Separation may result.

Sprinklers that are found to be leaking or exhibiting visible signs of corrosion must be replaced.

Automatic sprinklers must never be painted, plated, coated, or otherwise altered after leaving the factory. Modified sprinklers must be replaced. Sprinklers that have been exposed to corrosive products of combustion, but have not operated, should be replaced if they cannot be completely cleaned by wiping the sprinkler with a cloth or by brushing it with a soft bristle brush.

Care must be exercised to avoid damage to the sprinklers before, during, and after installation. Sprinklers damaged by dropping, striking, wrench twist/slippage, or the like, must be replaced. Also, replace any sprinkler that has a cracked bulb or that has lost liquid from its bulb - see the Installation Section.)

The owner is responsible for the inspection, testing, and maintenance of their fire protection system and devices in compliance with this document, as well as with the applicable standards of the National Fire Protection Association such as NFPA 25, in addition to the standards of any other authorities having jurisdiction. Contact the installing contractor or product manufacturer with any questions.

Automatic sprinkler systems should be inspected, tested, and maintained by a qualified Inspection Service in accordance with local requirements and/or national codes.

## Limited Warranty

For warranty terms and conditions, visit [www.tyco-fire.com](http://www.tyco-fire.com).

## Ordering Procedure

Contact your local distributor for availability. When placing an order, indicate the full product name and Part Number (P/N).

### Sprinkler Assembly

Specify: TY5522, (specify temperature rating) Model ELOC Pendent Sprinkler, P/N (specify):

<b>160°F (71°C)</b>	
TY5522	50-701-1-160
<b>212°F (100°C)</b>	
TY5522	50-701-1-212

### Separately Ordered Cover Plate

Specify: (specify temperature rating) Model ELOC Cover Plate with (specify finish), P/N (specify):

<b>139°F (59°C)<sup>(a)</sup></b>	
Grey White (RAL9002)	56-892-0-135
Brass	56-892-1-135
Pure White (RAL9010) <sup>(c)</sup>	56-892-3-135
Signal White (RAL9003)	56-892-4-135
Chrome	56-892-8-135
Custom	56-892-X-135
<b>165°F (74°C)<sup>(b)</sup></b>	
Grey White (RAL9002)	56-892-0-165
Brass	56-892-1-165
Pure White (RAL9010) <sup>(c)</sup>	56-892-3-165
Signal White (RAL9003)	56-892-4-165
Chrome	56-892-9-165
Custom	56-892-X-165

### NOTES

- a. For use with 160°F (71°C) sprinklers
- b. For use with 212°F (100°C) sprinklers
- c. Eastern Hemisphere sales only

### Sprinkler Wrench

Specify: W-Type 18 Sprinkler Wrench, P/N 56-000-1-265

### Air and Dust Seal

Specify: Air and Dust Seal, P/N 56-908-1-001



Worldwide  
Contacts | [www.tyco-fire.com](http://www.tyco-fire.com)

## **TFP250 Change History Appendix**

ISSUE DATE	NOTES
08-22	Page 1, added QR code and URL to allow convenient access to electronic version from printed document; Page 4, changed corporate address and telephone number to 1467 Elmwood Avenue, Cranston, RI 02910   Telephone +1-401-781-8220, formerly 1400 Pennbrook Parkway, Lansdale, PA 19446   Telephone +1-215-362-0700.
08-18	Updated Tyco® branding and document format; Added Johnson Controls copyright; Added disclaimer stating specifications and information subject to change without notice; Added reference to Regulatory and Health Warning Technical Data Sheet TFP2300.
05-17	Updated limited warranty information.
04-15	Corrected Optional Air and Dust Seal illustration caption to Figure 4, formerly Figure 5.
05-13	Updated and standardized RAL color finishes.
03-11	Updated patent information.
05-08	Changed Temperature Rating of Cover Plate to 139°F (59°C), formerly 135°F (57°C); Updated standard order cover plate finishes.
01-05	Added reference to Installer Warning data sheet TFP700; Added NYC Approved; Added White (RAL9010) finish for Eastern Hemisphere sales.
04-03	New Technical Data Sheet TFP250 describes Model ELOC Concealed Pendent Sprinkler.