

Type HV High Velocity Directional Spray Nozzles, Open, Non-Automatic

IMPORTANT

Refer to Technical Data Sheet TFP2300 for warnings pertaining to regulatory and health information.

Always refer to Technical Data Sheet TFP700 for the "INSTALLER WARNING" that provides cautions with respect to handling and installation of sprinkler systems and components. Improper handling and installation can permanently damage a sprinkler system or its components and cause the sprinkler to fail to operate in a fire situation or cause it to operate prematurely.

Scan the QR code or enter the URL in a web browser to access the most up-to-date electronic version of this document. Data rates may apply.



docs.jci.com/tycofire/TFP815

General Description

The Tyco Type HV Nozzles are open (non-automatic) directional spray nozzles with individual inlet strainers. They are designed for use in water spray fixed systems for fire protection applications where a high velocity water application may be required, such as for the protection of flammable liquids.

The Type HV Nozzles feature an integral strainer for use when the authority having jurisdiction (other than NFPA applications) requires the use of individual strainers in addition to main pipeline strainers for nozzles having an orifice diameter of 3/16 inch (4,8 mm) or less.

Available in brass or stainless steel, the six patterns of the Type HV Nozzles provide a wide variety of orifice sizes and distribution characteristics. As water passes through the internal swirl plate, a swirling action is produced, prior to the water being discharged through the orifice tip of the body, resulting in a solid conical spray pattern of water droplets being discharged over a defined area.

High velocity type nozzles are principally used in water spray systems for the protection of fixed hazards such as transformers, circuit breakers, diesel engines and diesel storage tanks, turbo alternators, lube oil systems, oil fire boilers, and similar hazards. They are capable of rapidly extinguishing oil fires by emulsification, cooling, and smothering. The surface cooling effects of high velocity type nozzles also minimizes the possibility of re-ignition after a fire extinguishment.

It is recommended that the end user be consulted with respect to the suitability of the materials of construction for any given corrosive environment. Effects of ambient temperature, concentration of chemicals, and gas/chemical velocity should be considered, at a minimum, along with the corrosive nature to which the nozzles may be exposed.

The TYCO Type HV Nozzles are a re-designation for the Gem Type HV.



NOTICE

The Tyco Type HV Nozzles described herein must be installed and maintained in compliance with this document, as well as with the applicable standards of the NATIONAL FIRE PROTECTION ASSOCIATION (NFPA), in addition to the standards of any other authorities having jurisdiction. Failure to do so may impair the performance of these devices.

The design of individual water spray fixed systems can vary considerably, depending on the characteristics and nature of the hazard, the basic purpose of the spraying system, the configuration of the hazard, and wind/draft conditions. Because of these variations as well as the wide range of available nozzle spray characteristics, the design of water spray fixed systems for fire protection must only be performed by experienced designers who thoroughly understand the limitations as well as capabilities of such systems.

The owner is responsible for maintaining their fire protection system and devices in proper operating condition. Contact the installing contractor or product manufacturer with any questions.

Model Number	Nominal Angle
HV-14	120°
HV-17	60°
HV-26	110°
HV-37	70°
HV-45	90°
HV-60	80°

TABLE A
NOMINAL SPRAY ANGLE
DATA

Technical Data

Approvals

UL and C-UL Listed
 FM Approved

Maximum Working Pressure

175 psi (12,1 bar)
 Refer to Graph A, Note 2

Discharge Coefficient

Refer to Figure 1

Water Distribution

Optimum flowing pressure is 30 to 80 psi
 (2,1 to 5,5 bar)

Refer to Graphs A and B

Thread Connection

Refer to Figure 1

Physical Characteristics

(Brass Assemblies)

Body Brass
 Swirl Plate Brass
 Strainer Brass
 Strainer Copper

Physical Characteristics

(Stainless Steel Assemblies)

Body Type 316
 Swirl Plate Type 316
 Strainer Type 316
 Strainer Type 316L

Type	K-Factor		Nominal Dimensions in Inches and (mm)				
	gpm/psi ^{1/2}	lpm/bar ^{1/2}	A	B	C	D	E-NPT*
HV-14	1.6	23,0	2.83 (71,9)	1.87 (47,1)	1.50 (38,1)	1.30 (33,0)	1
HV-17	1.8	25,9	2.83 (71,9)	1.87 (47,1)	1.50 (38,1)	1.30 (33,0)	1
HV-26	2.8	40,4	2.83 (71,9)	1.87 (47,1)	1.50 (38,1)	1.30 (33,0)	1
HV-37	4.3	62,0	3.00 (76,2)	2.03 (51,6)	1.50 (38,1)	1.30 (33,0)	1
HV-45	5.6	80,7	3.00 (76,2)	2.03 (51,6)	1.50 (38,1)	1.30 (33,0)	1
HV-60	6.4	92,2	4.56 (115,8)	3.41 (86,6)	1.90 (48,3)	1.65 (41,9)	1-1/4

* Pipe thread connections per ISO 7-1 can be provided on special request.

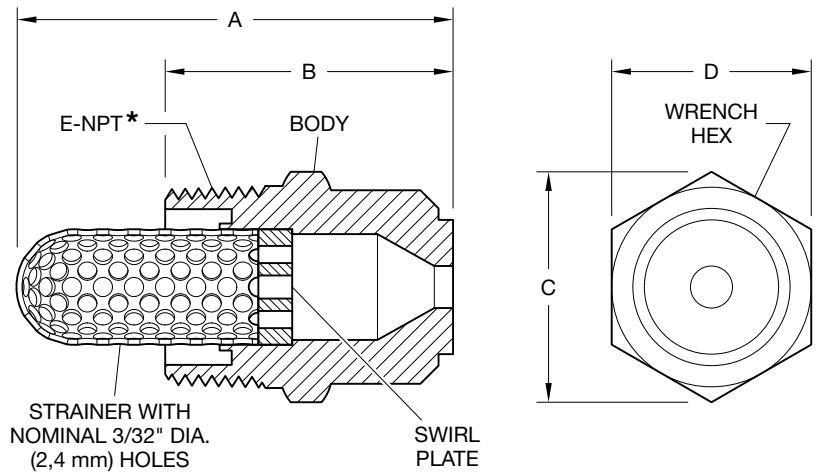

TYPE HV-14, HV-17, AND HV-26

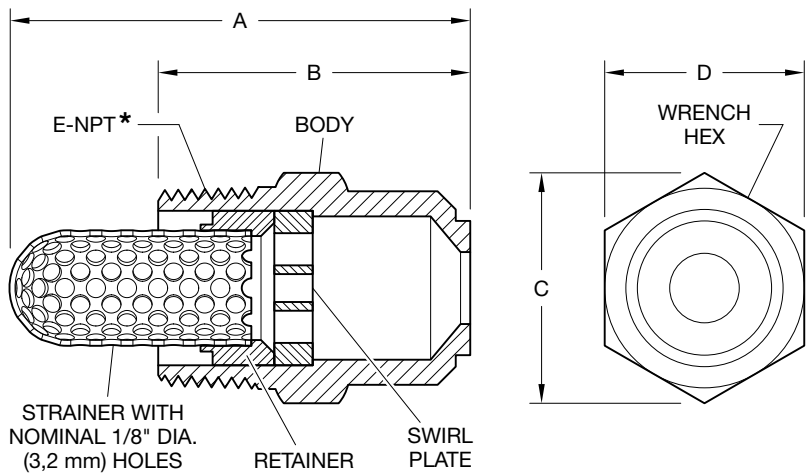

TYPE HV-37, HV-45, AND HV-60

FIGURE 1
TYPE HV NOZZLES
NOMINAL DIMENSIONS

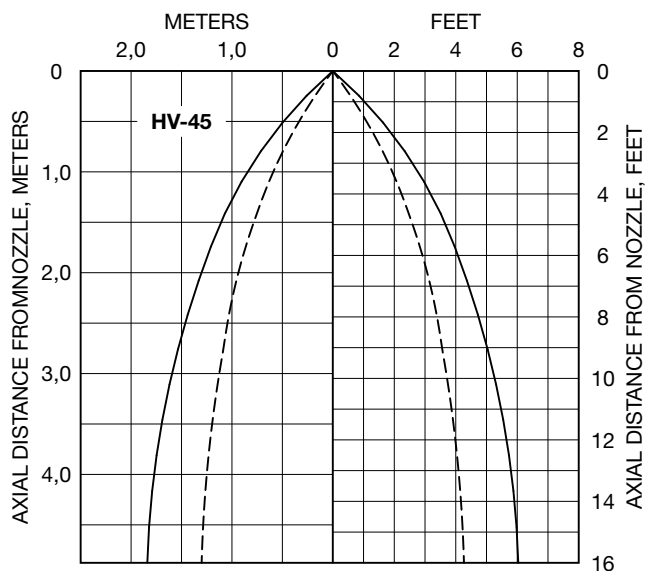
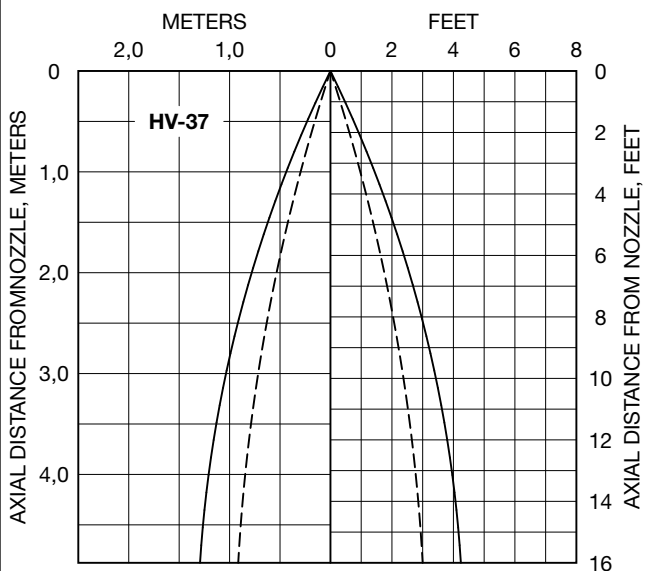
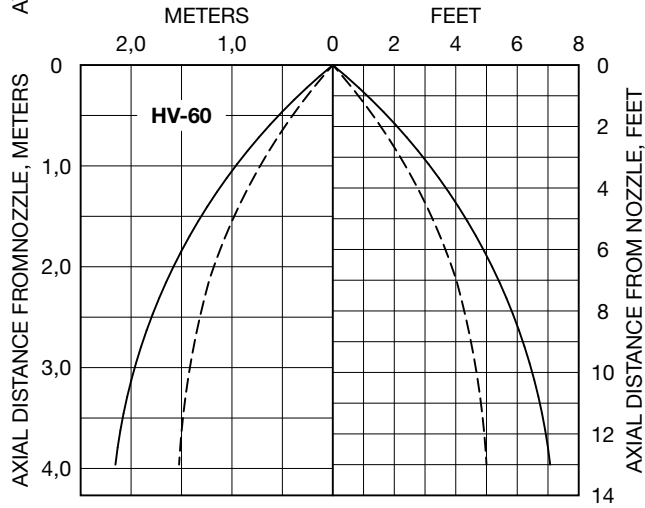
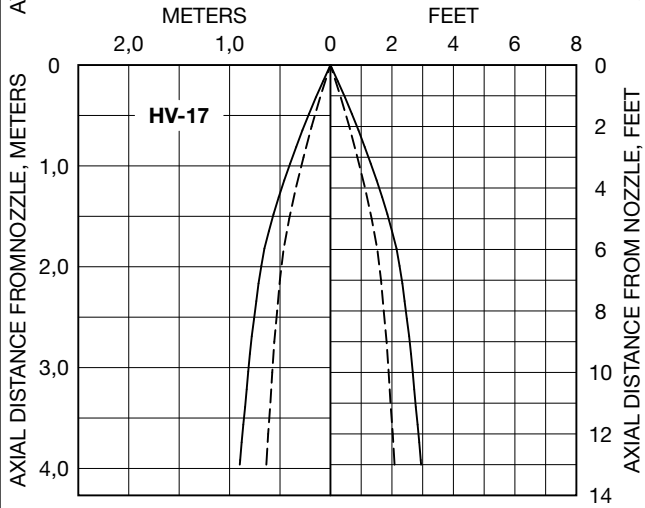
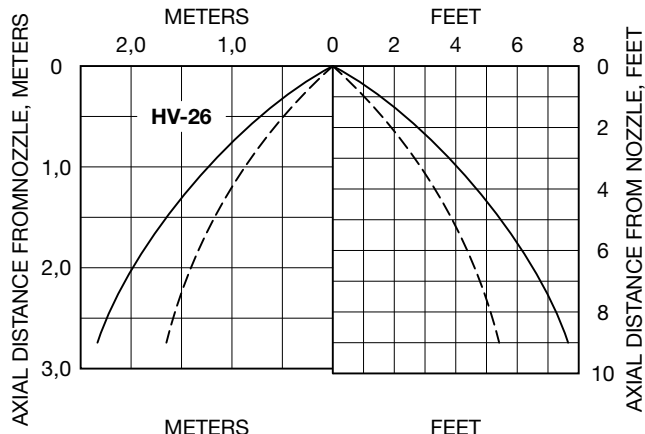
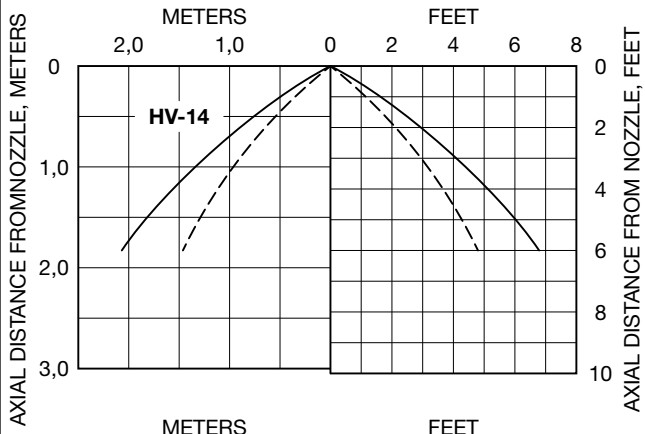
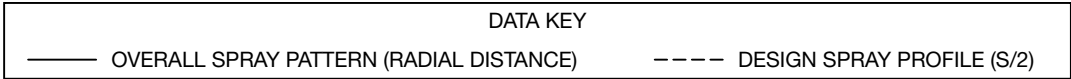

**GRAPH A – PART 1 OF 2
TYPE HV NOZZLES
WATER DISTRIBUTION DESIGN DATA**

NOTES (Graph A, Parts 1 and 2):

1. Design data applies to a maximum wind condition of 15 MPH (24 km/h).
2. Unless otherwise noted, design data applies to a residual (flowing) pressure range at the nozzle inlet of 30 to 80 psi (2,1 to 5,5 bar). For pressures up to 175 psi (12,1 bar), consult Tyco Fire Suppression & Building Products Technical Services.
3. The shapes of the Overall Spray Patterns and Design Spray Profiles remain essentially unchanged over the maximum recommended axial distances.

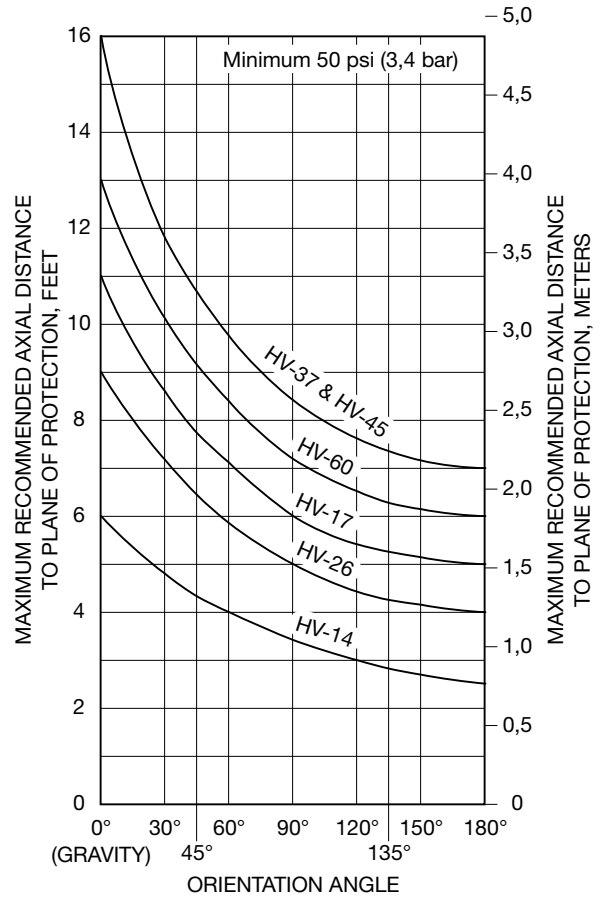
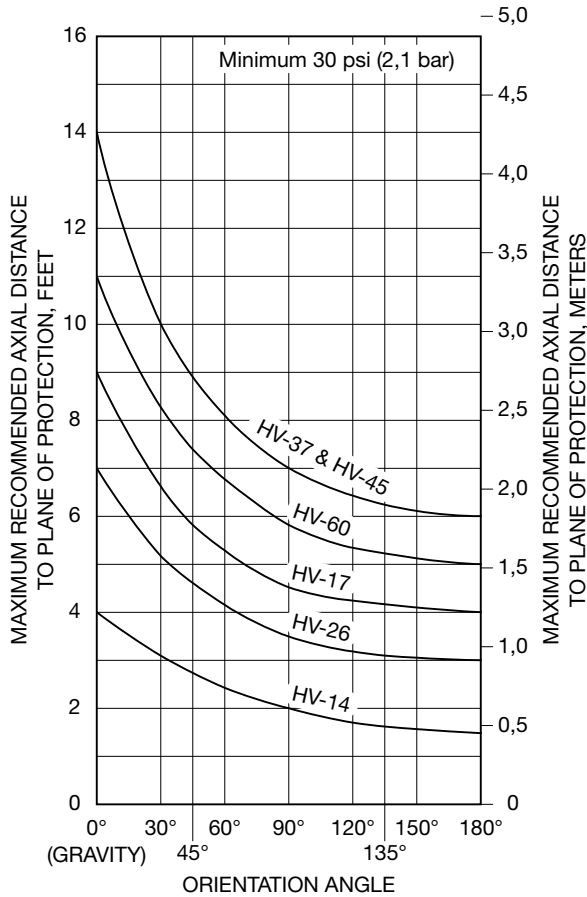
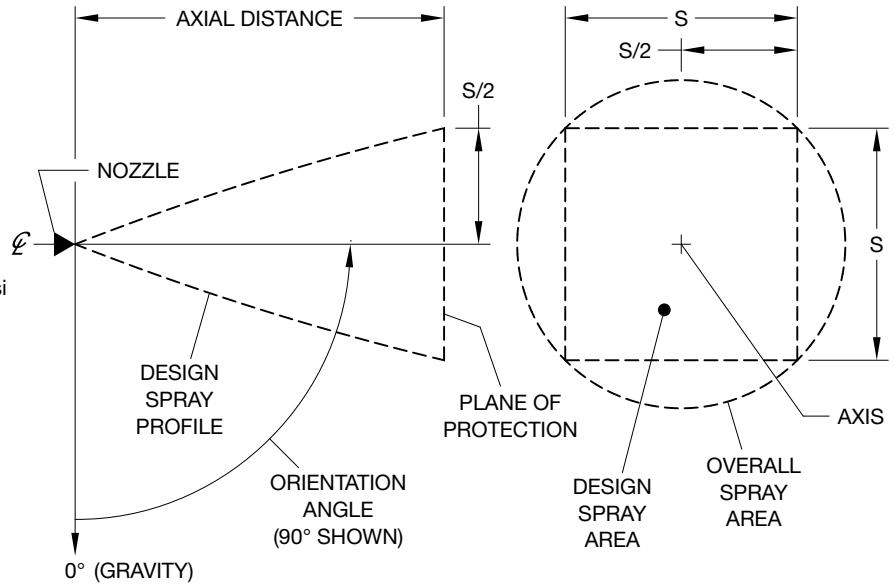

GRAPH A – PART 2 OF 2
TYPE HV NOZZLES
WATER DISTRIBUTION DESIGN DATA

NOTES:

1. Reference data applies to still air.
2. The Overall Spray Patterns in the plan view are the same as those in Figure 2, Part 1.

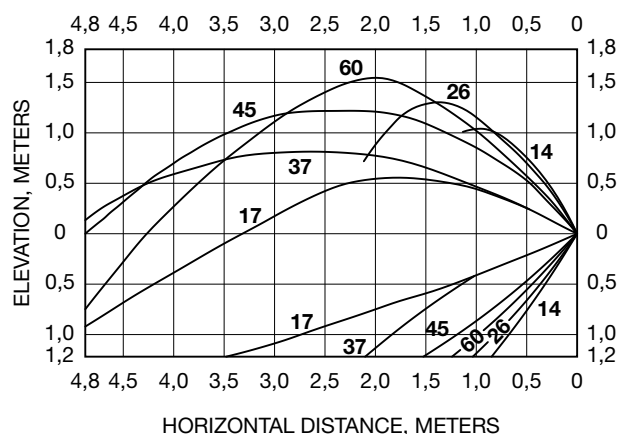
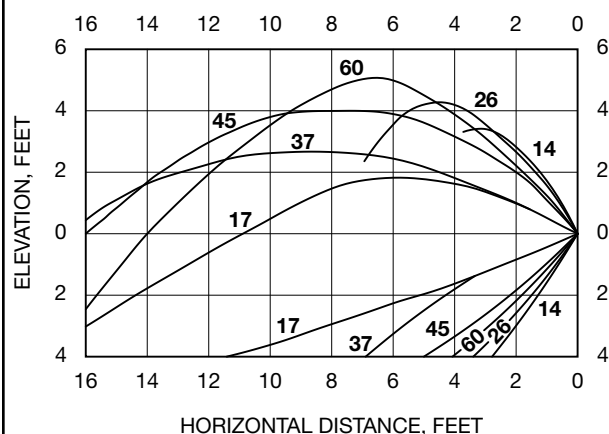

GRAPH B
TYPE HV NOZZLES
OVERALL VERTICAL SPRAY PATTERNS WHEN PROJECTING WATER
HORIZONTALLY BEYOND THE DESIGN PARAMETERS IN FIGURE 2
30 TO 80 PSI (2,1 TO 5,5 BAR)

Design Criteria

Nozzle Placement

The nominal overall spray patterns, spacing, and maximum recommended axial distances for six patterns of the Type HV Nozzles are given in Graph A for residual (flowing) pressures of 30 to 80 psi (2,1 to 5,5 bar). A minimum residual pressure of 30 psi (2,1 bar) can typically be used for most applications. However, a minimum residual pressure of 50 psi (3,4 bar) is recommended for applications requiring higher velocity water delivery, such as those specifying rapid extinguishment of oil fires by emulsification.

With reference to Graph A, use of the "Design Spray Profile" for the "Design Spray Area" will help assure that direct impingement on all surfaces will occur. The "Design Spray Area" shown at the

top Graph A - Part 2 of 2 on Page 4 consists of the square of length "S" within the circular "Overall Spray Area".

The maximum recommended axial distances given in Graph A are based on maintaining the specified spray patterns under a maximum wind condition of 15 MPH (24 km/h).

Graph B provides reference information showing the overall still air spray patterns beyond the maximum 15 MPH (24 km/h) axial distances, when projecting horizontally.

As shown in Graph B, the spray patterns become non-concentric, beyond a certain point, due to the affects of gravity.

Main Pipeline Strainers

Even though individual strainers have been provided, main pipeline strainers are required for systems utilizing Type HV Nozzles, since their waterways are less than 3/8 inch (9,5 mm) diameter.

Installation

TYCO Type HV Nozzles must be installed in accordance with this section.

General Instructions

A leak tight 1 inch NPT nozzle joint should be obtained by applying a minimum-to-maximum torque of 20 to 30 ft.-lbs. (26,8 to 40,2 N·m). A leak tight 1-1/4 inch NPT nozzle joint should be obtained by applying a minimum-to-maximum torque of 30 to 40 ft.-lbs. (40,2 to 53,6 N·m). Higher levels of torque can distort the nozzle inlet with consequent leakage or impairment of the nozzle.

Step 1. With pipe thread sealant applied to the pipe threads, hand tighten the nozzle into the nozzle fitting.

Step 2. Tighten the nozzle into the nozzle fitting using an adjustable crescent wrench. With reference to Figure 1 the adjustable crescent wrench is to be applied to the wrench hex.

Care and Maintenance

The TYCO Type HV High Velocity Nozzles must be maintained and serviced in accordance with this section.

Before closing a fire protection system main control valve for maintenance work on the fire protection system that it controls, obtain permission to shut down the affected fire protection system from the proper authorities and notify all personnel who may be affected by this action.

Sprinklers which are found to be leaking or exhibiting visible signs of corrosion must be replaced.

Automatic sprinklers must never be painted, plated, coated, or otherwise altered after leaving the factory. Modified sprinklers must be replaced. Sprinklers that have been exposed to corrosive products of combustion, but have not operated, should be replaced if they cannot be completely cleaned by wiping the sprinkler with a cloth or by brushing it with a soft bristle brush.

Care must be exercised to avoid damage to the sprinklers - before, during, and after installation. Sprinklers damaged by dropping, striking, wrench twist/slippage, or the like, must be replaced.

Water spray fixed systems for fire protection service require regularly scheduled care and maintenance by trained personnel. In addition to inspecting nozzles for proper spray performance during water flow trip tests of the system, it is recommended that nozzles be periodically inspected for broken or missing parts or evidence of impaired protection. The inspections should be scheduled weekly or as frequently as may be necessary, and corrective action must be taken to ensure that the nozzles will perform as intended in the event of a fire.

The owner is responsible for the inspection, testing, and maintenance of their fire protection system and devices in compliance with this document, as well as with the applicable standards of the NATIONAL FIRE PROTECTION ASSOCIATION (e.g., NFPA 25), in addition to the standards of any other authorities having jurisdiction. Contact the installing contractor or product manufacturer with any questions.

Water spray fixed systems are recommended to be inspected, tested, and maintained by a qualified Inspection Service in accordance with local requirements and/or national codes.

Limited Warranty

For warranty terms and conditions, visit www.tyco-fire.com.

Ordering Procedure

Contact your local distributor for availability. When placing an order, indicate the full product name and Part Number (P/N).

HV Nozzles

Specify: Type HV-(number), (specify brass or stainless steel) with (specify NPT or ISO 7-1) thread connection, P/N (specify):

Brass Assemblies, NPT

HV-14	49-014-1-001
HV-17	49-017-1-001
HV-26	49-026-1-001
HV-37	49-037-1-001
HV-45	49-045-1-001
HV-60	49-060-1-001

Stainless Steel Assemblies, NPT

HV-14	49-014-0-001
HV-17	49-017-0-001
HV-26	49-026-0-001
HV-37	49-037-0-001
HV-45	49-045-0-001
HV-60	49-060-0-001

Brass Assemblies, ISO 7-1

HV-14	PBP55062
HV-17	PBP55071
HV-26	PBP55080
HV-37	PBP55099
HV-45	PBP55101
HV-60	AEC00236

Stainless Steel Assemblies, ISO 7-1

HV-14	AEC00012
HV-17	AEC00021
HV-26	AEC00030
HV-37	AEC00049
HV-45	AEC00058
HV-60	AEC00263



TFP815 Change History Appendix

ISSUE DATE	NOTES
03-23	Page 2, Figure 1, data table, updated K-factor values for HV-26 nozzle to 2.8 (40,4), formerly 2.9 (41,8), and HV-45 nozzle to 5.6 (80,7), formerly 79,3).
08-22	Page 1, added QR code and URL to allow convenient access to electronic version from printed document; Page 6, changed corporate address and telephone number to 1467 Elmwood Avenue, Cranston, RI 02910 Telephone +1-401-781-8220, formerly 1400 Pennbrook Parkway, Lansdale, PA 19446 Telephone +1-215-362-0700.
11-19	Changed K-factor 5.6 to 5.5.
08-18	Updated Tyco® branding and document format; Added Johnson Controls copyright; Added disclaimer stating specifications and information subject to change without notice; Added reference to Regulatory and Health Warning Technical Data Sheet TFP2300.
11-16	Added Table A Nominal Spray Angle Data.
06-16	Update K-factors: HV-26 from 2.8 (40,3) to 2.9 (41,8); HV-37 from 4.6 (66,2) to 4.3 (62,0); and HV-45 from 5.5 (79,2) to 5.6 (80,7).
12-15	Updated HV-14, HV-17 and HV-26 orifice profile to generic appearance.
08-13	Changed part numbers consistent with Pricebook.
04-06	New Technical Data Sheet TFP815 describes Model HV-14 to HV-60 High Velocity Nozzles.