

## Type MV Directional Spray Nozzles, Open Medium Velocity

### IMPORTANT

Refer to Technical Data Sheet TFP2300 for warnings pertaining to regulatory and health information.

Always refer to Technical Data Sheet TFP700 for the "INSTALLER WARNING" that provides cautions with respect to handling and installation of sprinkler systems and components. Improper handling and installation can permanently damage a sprinkler system or its components and cause the sprinkler to fail to operate in a fire situation or cause it to operate prematurely.

Scan the QR code or enter the URL in a web browser to access the most up-to-date electronic version of this document. Data rates may apply.



[docs.jci.com/tycofire/TFP807](http://docs.jci.com/tycofire/TFP807)

## General Description

The TYCO Type MV Nozzles are open (non-automatic) directional spray nozzles designed for use in water spray fixed systems for fire protection applications. They are external deflector-type nozzles that discharge a uniformly filled cone of medium velocity water droplets.

The Type MV Nozzles are effective in covering exposed vertical, horizontal, curved, and irregular shaped surfaces in a cooling spray to prevent excessive absorption of heat from an external fire and possible structural damage or spread of fire to the protected equip-

ment. In some applications, depending on water design density requirements, the Type MV Nozzles may also be used for fire control or extinguishment.

The Type MV Nozzles are available in a wide variety of orifice sizes and spray angles (included angle of discharge) to provide versatility in system design.

The Type MV Nozzles having orifice diameters smaller than 9,5 mm (0.37 in.) are factory assembled with an orifice insert and strainer. Strainers have 3,2 mm (1/8 in.) diameter holes. Nozzles equipped with strainers range in size from MV10 to MV30 (Ref. Table A).

It is recommended that the end user be consulted with respect to the suitability of the materials of construction and finish for any given corrosive environment. The effects of ambient temperature, concentration of chemicals, and gas/chemical velocity, should be considered, at a minimum, along with the corrosive nature to which the Type MV Nozzles may be exposed.

### NOTICE

*The TYCO Type MV Nozzles described herein must be installed and maintained in compliance with this document and with the applicable standards of the NATIONAL FIRE PROTECTION ASSOCIATION (NFPA), in addition to the standards of any authorities having jurisdiction. Failure to do so may impair the performance of these devices.*

*The design of individual water spray fixed systems can vary considerably, depending on the characteristics and nature of the hazard, the basic purpose of the spraying system, the configuration of the hazard, and wind/draft conditions. Because of these variations, as well as the wide range of available nozzle spray characteristics, the design of water spray fixed systems for fire protection must only be performed by experienced designers who thoroughly understand the limitations as well as capabilities of such systems.*

*The owner is responsible for maintaining their fire protection system and devices in proper operating condition. Contact the installing contractor or product manufacturer with any questions.*



## Technical Data

### Approvals

Refer to Table A

### Maximum Working Pressure

12,1 bar (175 psi)  
(Refer to Figure 2, Note 2)

### Discharge Coefficient

Refer to Table A

### Spray Angles

Refer to Table B

### Thread Connection

1/2 in. NPT

### Physical Characteristics

MV Nozzles are comprised of components constructed from: Stainless Steel, Brass & Leaded Gunmetal LG2, Titanium, or 254 SMO.

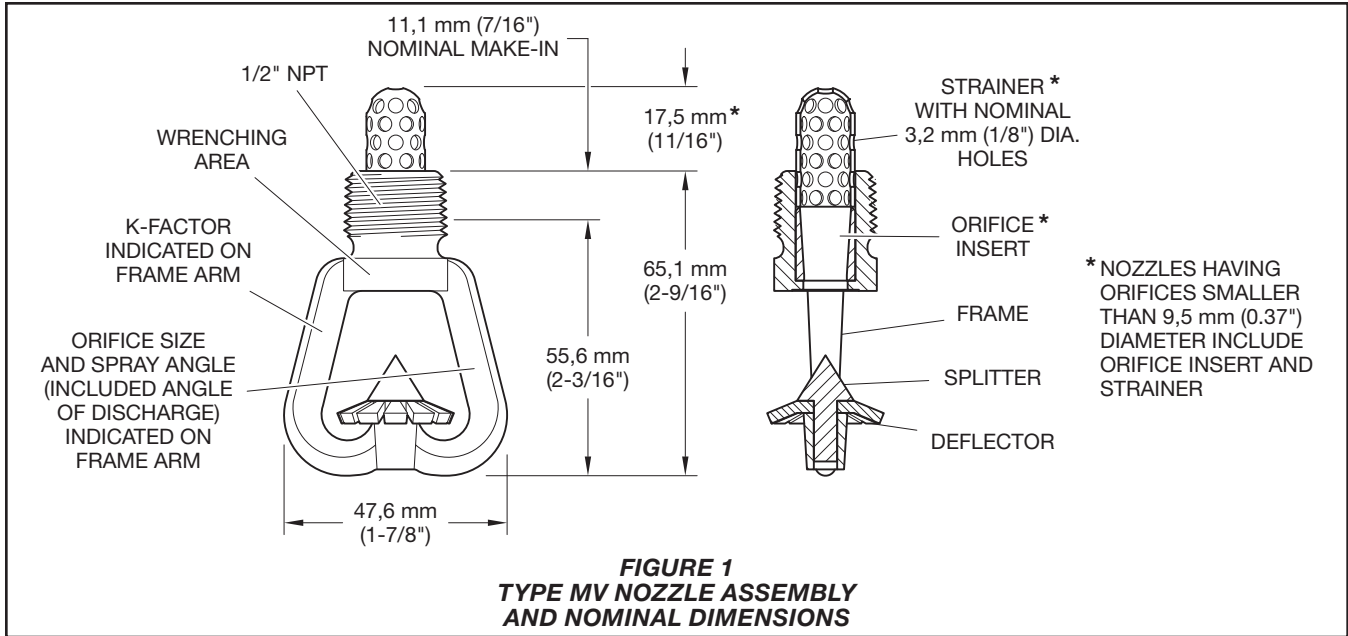

Orifice Size	Minimum Diameter mm (in.)	K-factor		Material			
		LPM/bar <sup>1/2</sup>	GPM/psi <sup>1/2</sup>	Stainless Steel	Brass and Leaded Gunmetal LG2	Titanium	SMO254
MV10	5,15 (0.20)	17,3	1.2	1, 2, 3	1, 2, 3	1, 3	1, 2, 3
MV12	5,40 (0.21)	18,7	1.3				
MV15	6,35 (0.25)	25,9	1.8				
MV18	6,80 (0.27)	28,8	2.0				
MV19	7,15 (0.28)	31,7	2.2				
MV21	7,70 (0.30)	36,0	2.5				
MV25	8,35 (0.33)	41,8	2.9				
MV26	8,80 (0.34)	44,6	3.1				
MV30	9,00 (0.35)	49,0	3.4				
MV34	9,60 (0.38)	59,0	4.1				
MV47	11,20 (0.44)	79,2	5.5				
MV57	12,60 (0.50)	100,8	7.0				

**NOTES:**  
 1. UL Listed  
 2. FM Approved  
 3. EAC Approved

**TABLE A**  
**TYPE MV NOZZLE ORIFICE SIZES, DISCHARGE COEFFICIENTS, MATERIALS OF CONSTRUCTION,**  
**AND LABORATORY LISTINGS AND APPROVALS**

90° 95° 110° 125° 140° 160°

**TABLE B**  
**TYPE MV NOZZLE SPRAY ANGLES**  
**(INCLUDED ANGLE OF DISCHARGE)**

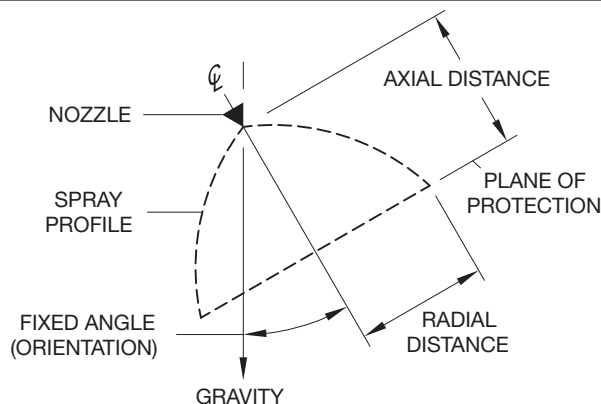

**NOTES:**

1. Design data obtained from tests in still air.
2. Design data applies to a residual (flowing) pressure range at the nozzle inlet of 1,4 to 4,1 bar (20 to 60 psi). For pressures up to 12,1 bar (175 psi) consult Tyco Fire Protection Products Technical Services.  
  
Refer to the authority having jurisdiction for their minimum required residual pressures.
3. The shapes of the Design Spray Profiles remain essentially unchanged over the maximum Axial Distances shown in Tables E and F.
4. For axial distances of 0,6 meters (2 feet) and less and for nozzle spray angles of 90° to 140°, the Design Spray Profile is the same as the nominal spray angle.
5. The maximum Axial Distances shown in Tables C and D are based on exposure protection.

**FIGURE 2**  
**WATER DISTRIBUTION DESIGN DATA**

## Design Criteria

### Nozzle Placement

Where direct impingement of water spray onto all of the protected surface is required by the authority having jurisdiction, TYCO Type MV Nozzles are to be spaced and directed so that their spray patterns will completely cover the plane-of-protection with the minimum required average density. However, it is recommended that indoor nozzle spacing be 3,7 m (12 ft) or less and that outdoor nozzle spacing be 3,0 m (10 ft) or less. Where rundown or slippage is planned, for example, exposure protection of vessels per NFPA 15, the above recommended indoor and outdoor spacings also apply.

When used for protecting the surfaces of a vessel, for example, MV nozzles are positioned normal to and approximately 0,6 m (2 ft) from the surface. This approach, in conjunction with a properly selected spray angle, will tend to make more effective use of the spray as well as help minimize the disturbance effects of wind/draft conditions on the water spray patterns.

### Spray Patterns

The Design Spray Profiles for MV nozzle spray angles of 90 to 160 degrees are shown in Graphs A through M and apply to discharge pressures of 1,4 to 4,1 bar (20 to 60 psi). Discharge pressures in excess of 4,1 bar (60 psi) will result in a decrease in coverage area since the spray patterns tend to draw inwards at higher pressures. The maximum axial distances between the nozzle tip and plane-of-protection, for exposure protection, are given in Table C and D.

When the axial distance from the nozzle tip to the plane-of-protection is 0,6 m (3 ft) or less, the Design Spray Profile is the same as the nominal spray angles of 90 to 140 degrees.

### Main Pipeline Strainers

Main pipeline strainers per NFPA 15 are required for systems utilizing nozzles with a flow path less than 9,5 mm (0.37 in.) diameter, that is, from MV10 to MV30 (Ref. Table A), and for any system where the water is likely to contain obstructive material.

## Installation

The TYCO Type MV Nozzles must be installed in accordance with this section.

### General Instructions

A leak-tight 1/2 in. NPT sprinkler joint should be obtained by applying a minimum-to-maximum torque of 9,5 to 19,0 N·m (7 to 14 ft·lb). Higher levels of torque can distort the nozzle Inlet with consequent impairment of the nozzle.

**Step 1.** With pipe-thread sealant applied to the pipe threads, hand-tighten the nozzle into the nozzle fitting.

**Step 2.** With reference to Figure 1, apply an appropriate size adjustable Crescent wrench to the wrenching area and tighten the nozzle into the nozzle fitting.

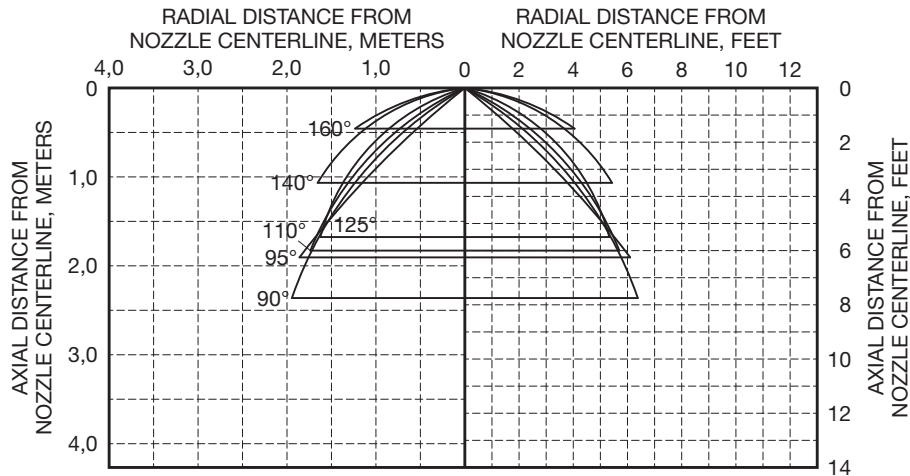

**GRAPH A**  
**TYPE MV10 DESIGN SPRAY PROFILES**  
**0° FIXED ANGLE, 4,1 BAR (60 PSI)**

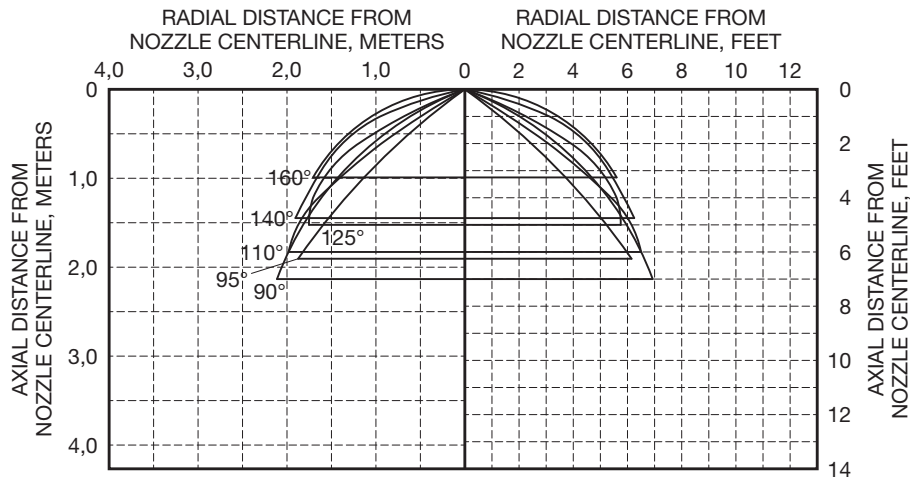

**GRAPH B**  
**TYPE MV12 DESIGN SPRAY PROFILES**  
**0° FIXED ANGLE, 4,1 BAR (60 PSI)**

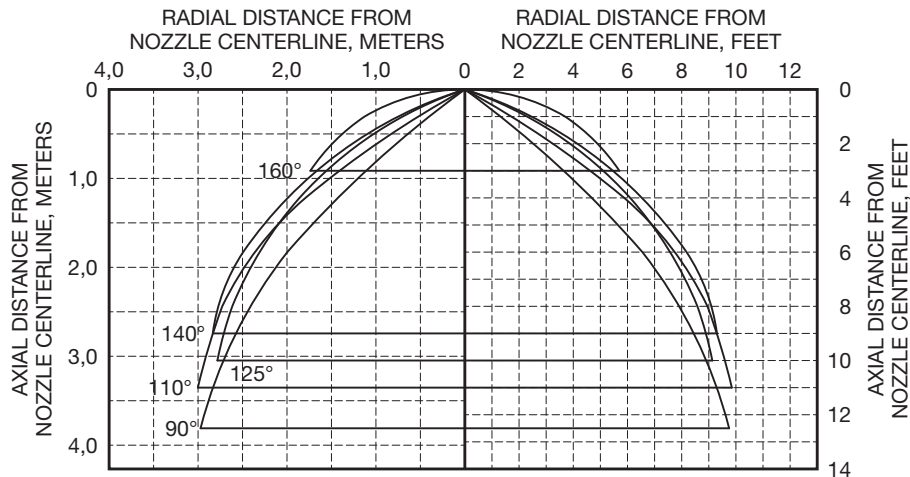

**GRAPH C**  
**TYPE MV15 DESIGN SPRAY PROFILES**  
**0° FIXED ANGLE, 4,1 BAR (60 PSI)**

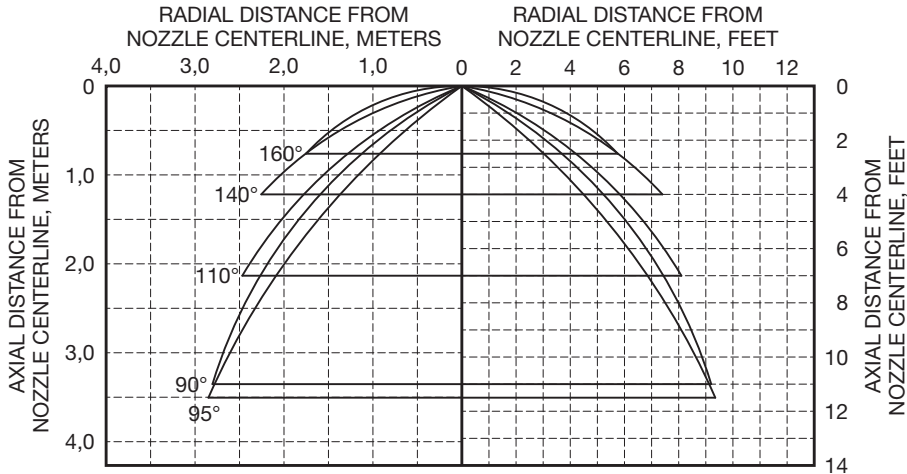

**GRAPH D**  
**TYPE MV18 DESIGN SPRAY PROFILES**  
**0° FIXED ANGLE, 4,1 BAR (60 PSI)**

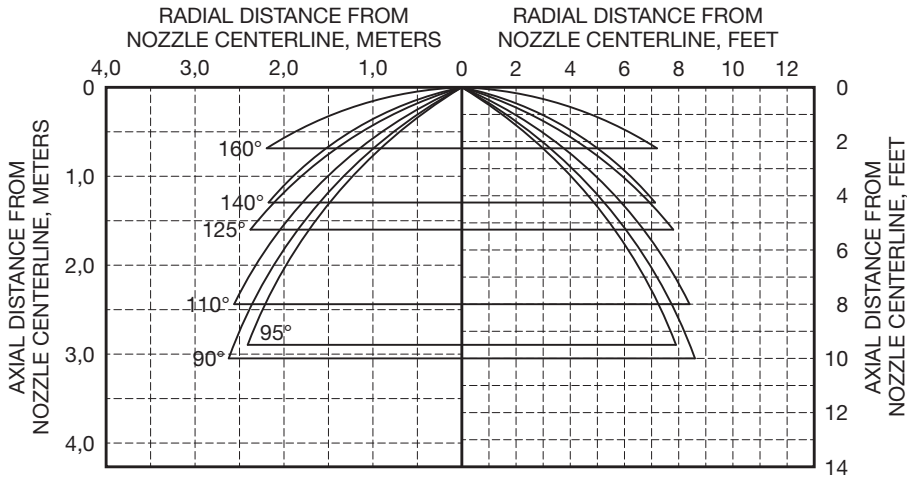

**GRAPH E**  
**TYPE MV19 DESIGN SPRAY PROFILES**  
**0° FIXED ANGLE, 4,1 BAR (60 PSI)**

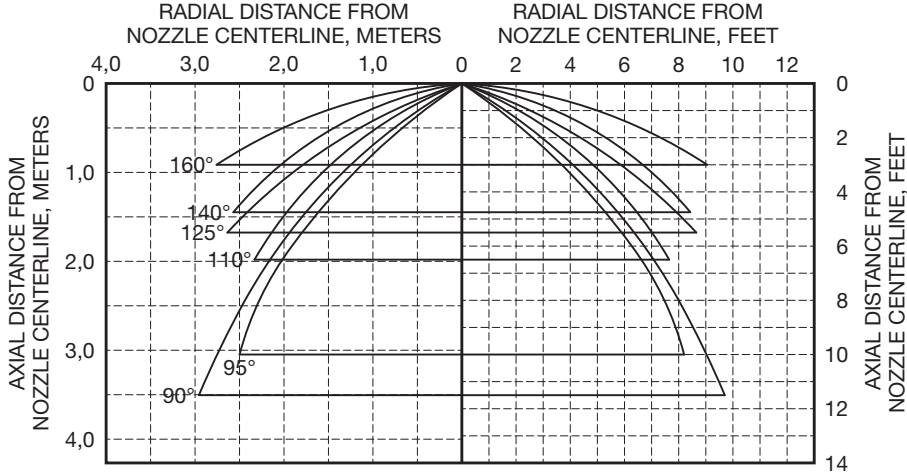

**GRAPH F**  
**TYPE MV21 DESIGN SPRAY PROFILES**  
**0° FIXED ANGLE, 4,1 BAR (60 PSI)**

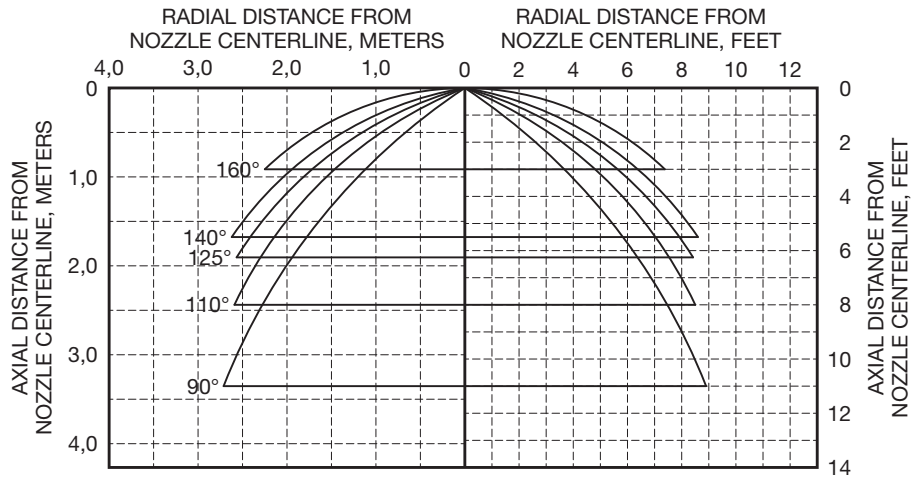

**GRAPH G**  
**TYPE MV25 DESIGN SPRAY PROFILES**  
**0° FIXED ANGLE, 4,1 BAR (60 PSI)**

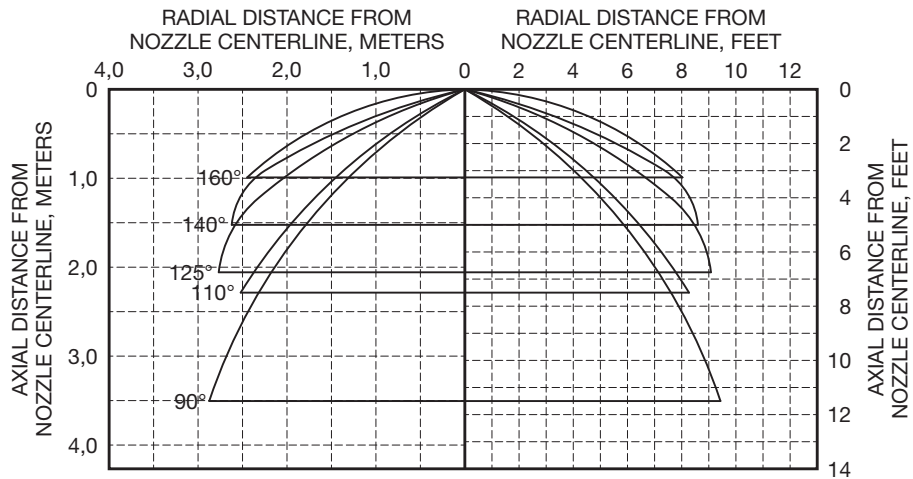

**GRAPH H**  
**TYPE MV26 DESIGN SPRAY PROFILES**  
**0° FIXED ANGLE, 4,1 BAR (60 PSI)**

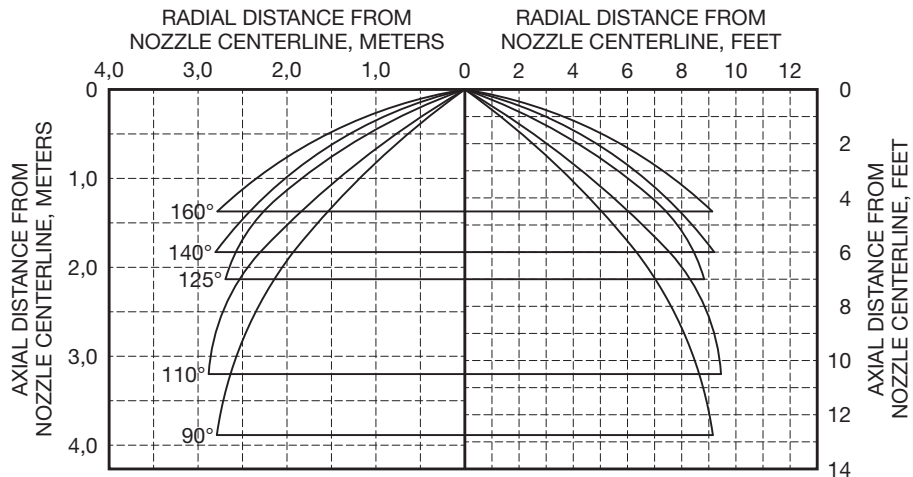

**GRAPH J**  
**TYPE MV30 DESIGN SPRAY PROFILES**  
**0° FIXED ANGLE, 4,1 BAR (60 PSI)**



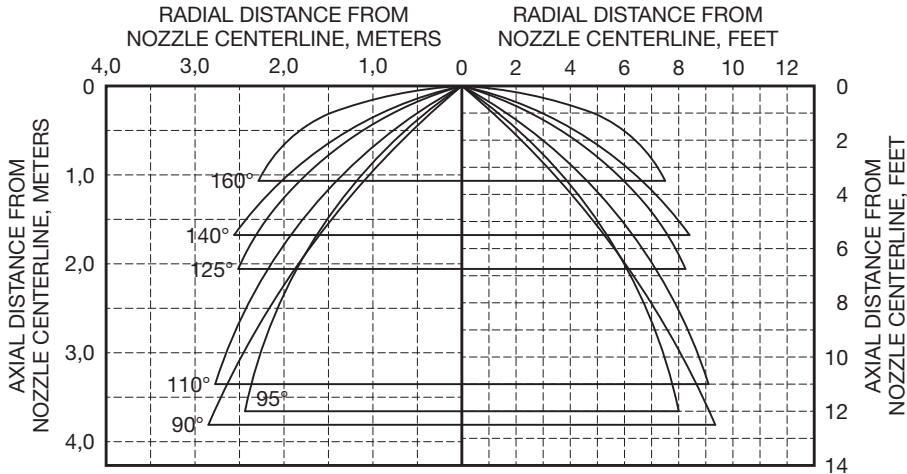

**GRAPH K**  
**TYPE MV34 DESIGN SPRAY PROFILES**  
**0° FIXED ANGLE, 4,1 BAR (60 PSI)**

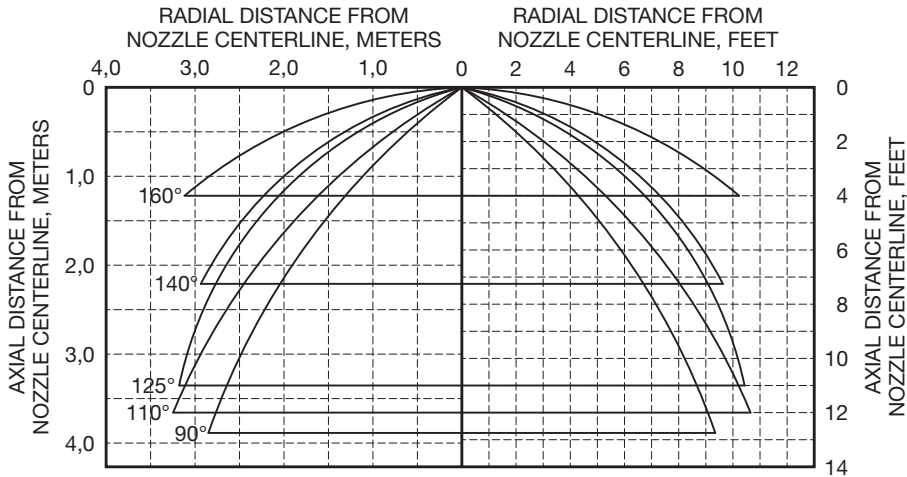

**GRAPH L**  
**TYPE MV47 DESIGN SPRAY PROFILES**  
**0° FIXED ANGLE, 4,1 BAR (60 PSI)**

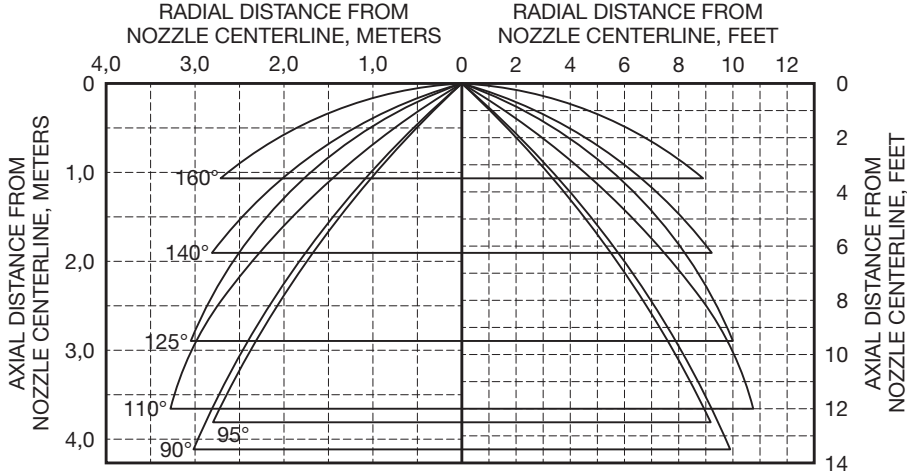

**GRAPH M**  
**TYPE MV57 DESIGN SPRAY PROFILES**  
**0° FIXED ANGLE, 4,1 BAR (60 PSI)**

Fixed Angle	MAXIMUM AXIAL DISTANCE FOR 90° SPRAY ANGLE IN METERS											
	Orifice Size											
	MV10	MV12	MV15	MV18	MV19	MV21	MV25	MV26	MV30	MV34	MV47	MV57
0°	2,4	2,1	3,8	3,7	3,0	3,5	3,4	3,5	3,9	3,8	3,9	4,1
45°	1,9	1,6	1,7	2,0	1,8	2,1	2,1	2,1	2,4	1,9	2,1	2,5
90°	1,0	1,1	1,3	1,5	1,7	1,7	1,5	1,4	1,7	1,7	1,8	2,3
135°	0,8	0,8	0,8	0,8	0,8	0,9	1,2	1,3	1,1	1,1	1,2	1,6
180°	0,5	0,5	0,5	0,8	0,8	0,8	0,8	0,8	1,0	0,9	1,1	1,4

Fixed Angle	MAXIMUM AXIAL DISTANCE FOR 95° SPRAY ANGLE IN METERS											
	Orifice Size											
	MV10	MV12	MV15	MV18	MV19	MV21	MV25	MV26	MV30	MV34	MV47	MV57
0°	1,9	1,9	3,6	3,5	2,9	3,0	2,7	2,7	3,5	3,7	3,7	3,8
45°	1,5	1,5	1,5	1,9	1,7	1,8	1,8	2,1	2,0	1,8	2,0	2,2
90°	0,9	1,0	1,2	1,4	1,5	1,2	1,4	1,4	1,6	1,6	1,7	2,1
135°	0,8	0,7	0,7	0,8	0,8	0,8	0,9	1,0	0,9	1,1	1,1	1,4
180°	0,5	0,5	0,5	0,6	0,7	0,5	0,7	0,7	0,8	0,8	1,0	1,2

Fixed Angle	MAXIMUM AXIAL DISTANCE FOR 110° SPRAY ANGLE IN METERS											
	Orifice Size											
	MV10	MV12	MV15	MV18	MV19	MV21	MV25	MV26	MV30	MV34	MV47	MV57
0°	1,8	1,8	3,4	2,1	2,4	2,0	2,4	2,3	3,2	3,0	3,7	3,7
45°	1,1	1,4	1,4	1,5	1,8	1,6	1,7	2,0	1,6	1,7	1,8	2,1
90°	0,8	0,9	1,1	1,2	1,2	1,2	1,3	1,3	1,5	1,5	1,6	1,8
135°	0,5	0,6	0,6	0,7	0,6	0,7	0,8	0,7	0,8	0,9	0,9	1,0
180°	0,4	0,3	0,4	0,5	0,5	0,5	0,6	0,6	0,7	0,8	0,8	0,8

**TABLE C (1 OF 2)**  
**MAXIMUM AXIAL DISTANCE BETWEEN NOZZLE TIP**  
**AND PLANE-OF-PROTECTION FOR EXPOSURE PROTECTION**  
**(METRIC)**



Fixed Angle	MAXIMUM AXIAL DISTANCE FOR 125° SPRAY ANGLE IN METERS											
	Orifice Size											
	MV10	MV12	MV15	MV18	MV19	MV21	MV25	MV26	MV30	MV34	MV47	MV57
0°	1,7	1,5	3,0	1,7	1,6	1,7	1,9	2,1	2,1	2,1	3,4	2,9
45°	1,1	1,3	1,4	1,2	1,4	1,4	1,4	1,4	1,3	1,5	1,3	1,8
90°	0,6	0,7	0,9	1,0	1,1	1,1	1,1	1,2	1,2	1,4	1,2	1,4
135°	0,5	0,5	0,5	0,5	0,5	0,5	0,6	0,6	0,7	0,8	0,8	0,8
180°	0,3	0,2	0,3	0,4	0,4	0,4	0,5	0,4	0,5	0,6	0,7	0,6

Fixed Angle	MAXIMUM AXIAL DISTANCE FOR 140° SPRAY ANGLE IN METERS											
	Orifice Size											
	MV10	MV12	MV15	MV18	MV19	MV21	MV25	MV26	MV30	MV34	MV47	MV57
0°	1,1	1,4	2,7	1,2	1,3	1,4	1,7	1,5	1,8	1,7	2,2	1,9
45°	0,8	1,0	1,3	0,9	1,1	1,1	1,3	1,1	1,2	1,3	1,2	1,7
90°	0,5	0,5	0,8	0,8	0,9	1,0	1,0	1,0	1,0	1,1	1,1	1,2
135°	0,4	0,4	0,4	0,4	0,4	0,4	0,5	0,5	0,5	0,8	0,6	0,7
180°	0,2	0,2	0,2	0,3	0,2	0,3	0,4	0,3	0,4	0,5	0,6	0,5

Fixed Angle	MAXIMUM AXIAL DISTANCE FOR 160° SPRAY ANGLE IN METERS											
	Orifice Size											
	MV10	MV12	MV15	MV18	MV19	MV21	MV25	MV26	MV30	MV34	MV47	MV57
0°	0,5	1,0	0,9	0,8	0,7	0,9	0,9	1,0	1,1	1,1	1,2	1,4
45°	0,5	0,5	0,7	0,8	0,5	0,6	0,8	0,9	1,1	1,1	1,1	1,1
90°	0,2	0,4	0,4	0,7	0,7	0,7	0,7	0,8	0,8	0,8	0,8	1,1
135°	0,2	0,3	0,2	0,2	0,3	0,2	0,2	0,2	0,3	0,5	0,5	0,5
180°	0,2	0,1	0,2	0,2	0,2	0,2	0,2	0,2	0,2	0,4	0,5	0,4

**TABLE C (2 OF 2)**  
**MAXIMUM AXIAL DISTANCE BETWEEN NOZZLE TIP**  
**AND PLANE-OF-PROTECTION FOR EXPOSURE PROTECTION**  
**(METRIC)**

Fixed Angle	MAXIMUM AXIAL DISTANCE FOR 90° SPRAY ANGLE IN FEET AND INCHES											
	Orifice Size											
	MV10	MV12	MV15	MV18	MV19	MV21	MV25	MV26	MV30	MV34	MV47	MV57
0°	7-9	7-0	12-6	12-0	10-0	11-6	11-0	11-6	12-9	12-6	12-9	13-6
45°	6-3	5-3	5-6	6-6	5-9	6-9	7-0	7-0	7-9	6-3	7-0	8-3
90°	3-3	3-6	4-3	5-0	5-6	5-6	5-0	4-9	5-6	5-6	6-0	7-6
135°	2-9	2-6	2-6	2-9	2-9	3-0	4-0	4-3	3-6	3-9	4-0	5-3
180°	1-9	1-9	1-9	2-6	2-9	2-9	2-6	2-9	3-3	3-0	3-9	4-6

Fixed Angle	MAXIMUM AXIAL DISTANCE FOR 95° SPRAY ANGLE IN FEET AND INCHES											
	Orifice Size											
	MV10	MV12	MV15	MV18	MV19	MV21	MV25	MV26	MV30	MV34	MV47	MV57
0°	6-3	6-3	11-9	11-6	9-6	10-0	9-0	9-0	11-6	12-0	12-3	12-6
45°	5-0	5-0	5-0	6-3	5-6	6-0	6-0	6-9	6-6	6-0	6-6	7-3
90°	3-0	3-3	4-0	4-6	5-0	4-0	4-6	4-6	5-3	5-3	5-6	6-9
135°	2-6	2-3	2-3	2-6	2-6	2-6	3-0	3-3	3-0	3-6	3-6	4-9
180°	1-6	1-6	1-6	2-0	2-3	1-9	2-3	2-3	2-6	2-9	3-3	4-0

Fixed Angle	MAXIMUM AXIAL DISTANCE FOR 110° SPRAY ANGLE IN FEET AND INCHES											
	Orifice Size											
	MV10	MV12	MV15	MV18	MV19	MV21	MV25	MV26	MV30	MV34	MV47	MV57
0°	6-0	6-0	11-0	7-0	8-0	6-6	8-0	7-6	10-6	10-0	12-0	12-0
45°	3-9	4-6	4-9	5-0	5-9	5-3	5-6	6-6	5-3	5-6	6-0	7-0
90°	2-9	3-0	3-9	4-0	4-0	4-0	4-3	4-3	5-0	5-0	5-3	5-9
135°	1-9	2-0	2-0	2-3	2-0	2-3	2-6	2-3	2-6	3-0	3-0	3-3
180°	1-3	1-0	1-3	1-6	1-9	1-6	2-0	2-0	2-3	2-6	2-9	2-9

**TABLE D (1 OF 2)**  
**MAXIMUM AXIAL DISTANCE BETWEEN NOZZLE TIP**  
**AND PLANE-OF-PROTECTION FOR EXPOSURE PROTECTION**  
**(IMPERIAL)**

Fixed Angle	MAXIMUM AXIAL DISTANCE FOR 125° SPRAY ANGLE IN FEET AND INCHES											
	Orifice Size											
	MV10	MV12	MV15	MV18	MV19	MV21	MV25	MV26	MV30	MV34	MV47	MV57
0°	5-6	5-0	10-0	5-6	5-3	5-6	6-3	6-9	7-0	6-9	11-0	9-6
45°	3-6	4-3	4-6	4-0	4-6	4-6	4-9	4-6	4-3	5-0	4-3	5-9
90°	2-0	2-3	3-0	3-3	3-6	3-6	3-9	4-0	4-0	4-9	4-0	4-6
135°	1-6	1-6	1-6	1-9	1-6	1-6	2-0	2-0	2-3	2-9	2-9	2-6
180°	1-0	0-9	1-0	1-3	1-3	1-3	1-6	1-3	1-9	2-0	2-3	2-0

Fixed Angle	MAXIMUM AXIAL DISTANCE FOR 140° SPRAY ANGLE IN FEET AND INCHES											
	Orifice Size											
	MV10	MV12	MV15	MV18	MV19	MV21	MV25	MV26	MV30	MV34	MV47	MV57
0°	3-6	4-9	9-0	4-0	4-3	4-9	5-6	5-0	6-0	5-6	7-3	6-3
45°	2-9	3-3	4-3	3-0	3-9	3-9	4-3	3-6	4-0	4-3	4-0	5-6
90°	1-6	1-9	2-6	2-6	3-0	3-3	3-3	3-3	3-3	3-6	3-9	4-0
135°	1-3	1-3	1-3	1-3	1-3	1-3	1-6	1-9	1-6	2-6	2-0	2-3
180°	0-9	0-6	0-9	1-0	0-9	1-0	1-3	1-0	1-3	1-6	2-0	1-9

Fixed Angle	MAXIMUM AXIAL DISTANCE FOR 160° SPRAY ANGLE IN FEET AND INCHES											
	Orifice Size											
	MV10	MV12	MV15	MV18	MV19	MV21	MV25	MV26	MV30	MV34	MV47	MV57
0°	1-6	3-3	3-0	2-6	2-3	3-0	3-0	3-3	3-6	3-6	4-0	4-6
45°	1-6	1-6	2-3	2-6	1-9	2-0	2-9	3-0	3-6	3-9	3-6	3-9
90°	0-9	1-3	1-3	2-3	2-3	2-3	2-3	2-6	2-6	2-6	2-9	3-6
135°	0-6	1-0	0-9	0-9	1-0	0-9	0-9	0-9	1-0	1-6	1-6	1-6
180°	0-6	0-3	0-6	0-9	0-6	0-6	0-6	0-6	0-6	1-3	1-6	1-3

**TABLE D (2 OF 2)**  
**MAXIMUM AXIAL DISTANCE BETWEEN NOZZLE TIP**  
**AND PLANE-OF-PROTECTION FOR EXPOSURE PROTECTION**  
**(IMPERIAL)**

<b>Stainless Steel</b>						
<b>Orifice Size</b>	<b>Spray Angle</b>					
	<b>90°</b>	<b>95°</b>	<b>110°</b>	<b>125°</b>	<b>140°</b>	<b>160°</b>
MV10	AED07603	AED00024	AED00033	AED00042	AED00051	AED02560
MV12	AED07612	AED07621	AED07630	AED07649	AED07658	AED07667
MV15	AED07676	AED00088	AED00097	AED00109	AED00118	AED00127
MV18	AED07685	AED07694	AED07706	AED07715	AED07724	AED07733
MV19	AED07742	AED00145	AED00154	AED00163	AED00172	AED00181
MV21	AED07760	AED07779	AED07788	AED07797	AED07809	AED07818
MV25	AED07751	AEA00202	AEA00211	AED00220	AEA00239	AEA00248
MV26	AED07827	AED07836	AED07845	AED07854	AED07863	AED07872
MV30	AED07881	AED07890	AED07902	AED07911	AED07920	AED07939
MV34	AED07948	AED01218	AED01227	AED01236	AED01245	AED01254
MV47	AED07957	AED01272	AED01281	AED01290	AED01302	AED01311
MV57	AED07966	AED01339	AED01348	AED01357	AED01366	AED01375

<b>Brass and Leaded Gunmetal LG2</b>						
<b>Orifice Size</b>	<b>Spray Angle</b>					
	<b>90°</b>	<b>95°</b>	<b>110°</b>	<b>125°</b>	<b>140°</b>	<b>160°</b>
MV10	AED03829	AEA02524	AEA02533	AEA02542	AEA02551	AEA02560
MV12	AED03838	AED03847	AED03856	AED03865	AED03874	AED03883
MV15	AED03892	AEA02588	AEA02597	AEA02609	AEA02618	AEA02627
MV18	AED03904	AED03913	AED03922	AED03931	AED03940	AED03959
MV19	AED03968	AEA02645	AEA02654	AEA02663	AEA02672	AEA02681
MV21	AED03977	AED03986	AED03995	AED04004	AED04013	AED04022
MV25	AED04031	AEA02702	AEA02711	AEA02720	AEA02739	AEA02748
MV26	AED04040	AED04059	AED04068	AED04077	AED04086	AED04095
MV30	AED04107	AED04116	AED04125	AED04134	AED04143	AED04152
MV34	AED04161	AED00949	AED00958	AED00967	AED00976	AED00985
MV47	AED04170	AED01003	AED01012	AED01021	AED01030	AED01049
MV57	AED04189	AED01067	AED01076	AED01085	AED01094	AED01106

<b>Titanium</b>						
<b>Orifice Size</b>	<b>Spray Angle</b>					
	<b>90°</b>	<b>95°</b>	<b>110°</b>	<b>125°</b>	<b>140°</b>	<b>160°</b>
MV10	AED07603T	AED00024T	AED00033T	AED00042T	AED00051T	AED02560T
MV12	AED07612T	AED07621T	AED07630T	AED07649T	AED07658T	AED07667T
MV15	AED07676T	AED00088T	AED00097T	AED00109T	AED00118T	AED00127T
MV18	AED07685T	AED07694T	AED07706T	AED07715T	AED07724T	AED07733T
MV19	AED07742T	AED00145T	AED00154T	AED00163T	AED00172T	AED00181T
MV21	AED07760T	AED07779T	AED07788T	AED07797T	AED07809T	AED07818T
MV25	AED07751T	AEA00202T	AEA00211T	AED00220T	AEA00239T	AEA00248T
MV26	AED07827T	AED07836T	AED07845T	AED07854T	AED07863T	AED07872T
MV30	AED07881T	AED07890T	AED07902T	AED07911T	AED07920T	AED07939T
MV34	AED07948T	AED01218T	AED01227T	AED01236T	AED01245T	AED01254T
MV47	AED07957T	AED01272T	AED01281T	AED01290T	AED01302T	AED01311T
MV57	AED07966T	AED01339T	AED01348T	AED01357T	AED01366T	AED01375T

**TABLE E (1 OF 2)**  
**TYPE MV NOZZLE**  
**PART NUMBERS**

254 SMO						
Orifice Size	Spray Angle					
	90°	95°	110°	125°	140°	160°
MV10	AED07603SMO	AED00024SMO	AED00033SMO	AED00042SMO	AED00051SMO	AED02560SMO
MV12	AED07612SMO	AED07621SMO	AED07630SMO	AED07649SMO	AED07658SMO	AED07667SMO
MV15	AED07676SMO	AED00088SMO	AED00097SMO	AED00109SMO	AED00118SMO	AED00127SMO
MV18	AED07685SMO	AED07694SMO	AED07706SMO	AED07715SMO	AED07724SMO	AED07733SMO
MV19	AED07742SMO	AED00145SMO	AED00154SMO	AED00163SMO	AED00172SMO	AED00181SMO
MV21	AED07760SMO	AED07779SMO	AED07788SMO	AED07797SMO	AED07809SMO	AED07818SMO
MV25	AED07751SMO	AEA00202SMO	AEA00211SMO	AED00220SMO	AEA00239SMO	AEA00248SMO
MV26	AED07827SMO	AED07836SMO	AED07845SMO	AED07854SMO	AED07863SMO	AED07872SMO
MV30	AED07881SMO	AED07890SMO	AED07902SMO	AED07911SMO	AED07920SMO	AED07939SMO
MV34	AED07948SMO	AED01218SMO	AED01227SMO	AED01236SMO	AED01245SMO	AED01254SMO
MV47	AED07957SMO	AED01272SMO	AED01281SMO	AED01290SMO	AED01302SMO	AED01311SMO
MV57	AED07966SMO	AED01339SMO	AED01348SMO	AED01357SMO	AED01366SMO	AED01375SMO

**TABLE E (2 OF 2)**  
**TYPE MV NOZZLE**  
**PART NUMBERS**

## Care and Maintenance

The Tyco Type MV Nozzles must be maintained and serviced in accordance with this section.

Before closing a fire protection system main control valve for maintenance work on the fire protection system that it controls, obtain permission to shut down the affected fire protection system from the proper authorities and notify all personnel who may be affected by this action.

Type MV Nozzles must never be painted, plated, coated or altered in any way after leaving the factory; otherwise, the spray performance may be impaired.

Exercise care to avoid damage to the nozzles, before, during, and after installation. Replace nozzles damaged by dropping, striking, wrench twist/slip-page, or the like.

Frequent visual inspections are recommended to be initially performed for nozzles installed in potentially corrosive atmospheres to verify the integrity of the materials of construction and finish as they may be affected by the corrosive conditions present for a given installation. Thereafter, annual inspections per NFPA 25 are required.

Water spray fixed systems to fire protection service require regularly scheduled care and maintenance by trained personnel.

In addition to inspecting nozzles for proper spray performance during water flow trip tests of the system, it is recommended that nozzles be periodically inspected for broken or missing parts, loading/obstructions, or other evidence of impaired protection. The inspections should be scheduled weekly or as frequently as may be necessary, and corrective action must be taken to ensure that the nozzles will perform as intended in the event of a fire.

The owner is responsible for the inspection, testing, and maintenance of their fire protection system and devices in compliance with this document, as well as with the applicable standards of the NATIONAL FIRE PROTECTION ASSOCIATION (for example, NFPA 25), in addition to the standards of any authorities having jurisdiction. Contact the installing contractor or product manufacturer with any questions.

Water spray fixed systems are recommended to be inspected, tested, and maintained by a qualified Inspection Service in accordance with local requirements and/or national codes.

## Limited Warranty

For warranty terms and conditions, visit [www.tyco-fire.com](http://www.tyco-fire.com).

## Ordering Procedure

Contact your local distributor for availability. When placing an order, indicate the full product name and part number (P/N).

### Type MV Nozzles

Specify: Type MV Directional Spray Nozzle, Open, Medium Velocity, orifice size (specify), material (specify), spray angle (specify degrees), P/N (specify from Table E).





## TFP807 Change History Appendix

ISSUE DATE	NOTES
06-23	Page 12, Table E, updated part numbers. Stainless Steel nozzles: MV10 95° to AED00024, formerly AEA00024; 125° to AED00042, formerly AEA00042; 140° to AED00051, formerly AEA00051; 160° to AED02560, formerly AEA02560; MV15 95° to AED00088, formerly AEA00088; 140° to AED00118, formerly AEA00118; 160° to AED00127, formerly AEA00127; MV19 95° to AED00145, formerly AEA00145; 140° to AED00172, formerly AEA00172. Titanium nozzles: MV10 95° to AED00024T, formerly AEA00024T; 125° to AED00042T, formerly AEA00042T; 140° to AED00051T, formerly AEA00051T; 160° to AED02560T, formerly AEA02560T; MV15 95° to AED00088T, formerly AEA00088T; 140° to AED00118T, formerly AEA00118T; 160° to AED00127T, formerly AEA00127T; MV19 95° to AED00145T, formerly AEA00145T; 140° to AED00172T, formerly AEA00172T.
08-22	Page 1, updated QR code and URL; Page 14, changed corporate address and telephone number to 1467 Elmwood Avenue, Cranston, RI 02910   Telephone +1-401-781-8220, formerly 1400 Pennbrook Parkway, Lansdale, PA 19446   Telephone +1-215-362-0700.
03-22	Page 1, added QR code and URL to allow convenient access to electronic version from printed document; Page 2, Table A, added EAC Approved; Page 3, Spray Pattern sub-section, removed statement Refer inquiries on higher discharge pressures to the Technical Services Department.
08-18	Updated Tyco® branding and document format; Added Johnson Controls copyright; Added disclaimer stating specifications and information subject to change without notice; Added reference to Regulatory and Health Warning Technical Data Sheet TFP2300.
01-18	Update part number prefix AED to AEA for nozzles featuring Brass and Lead Gunmetal material, orifice sizes MV10, MV15 and MV19 and spray angles 95° through 160°.
10-15	Removed Aluminum Bronze and Zeron 100 materials; Change part number for Brass Type MV10 110° Spray Angle Nozzle in Table E to AEA02533, formerly shown as AED02533.
07-14	Updated spray profile for MV57 160° nozzle in Graph M with profile from 4.1 bar (60 psi) spray test, replacing profile from 12.1 bar (175 psi) spray test; Changed part number for MV19-125 nozzle Brass and Lead Gunmetal LG2 material in Table E Part 1 to AEA02263, formerly shown as AED02263.
04-14	New Technical Data Sheet TFP807 describes Type MV Medium Velocity Open Nozzles.