

Model TY-QRF – 5.6 K-factor Flush Pendent Sprinkler Quick Response, Standard Coverage

General Description

TYCO Model TY-QRF 5.6K Quick Response, Standard Coverage, Flush Pendent Sprinklers are decorative, fusible solder-type sprinklers. They are designed for use in commercial light and ordinary hazard occupancies such as offices and restaurants. When aesthetics is the major consideration, the TY-QRF should be your first choice.

The TY-QRF features a separable escutcheon providing 3/8 inch (9,5 mm) vertical adjustment. This adjustment reduces the accuracy to which the fixed pipe drops to the sprinklers must be cut to help assure a perfect fit installation.

NOTICE

The Model TY-QRF Flush Pendent Sprinklers described herein must be installed and maintained in compliance with this document, as well as with the applicable standards of the National Fire Protection Association, in addition to the standards of any authorities having jurisdiction. Failure to do so may impair the performance of these devices.

The owner is responsible for maintaining their fire protection system and devices in proper operating condition. Contact the installing contractor or product manufacturer with any questions.

IMPORTANT

Always refer to Technical Data Sheet TFP700 for the "INSTALLER WARNING" that provides cautions with respect to handling and installation of sprinkler systems and components. Improper handling and installation can permanently damage a sprinkler system or its components and cause the sprinkler to fail to operate in a fire situation or cause it to operate prematurely.

Sprinkler Identification Number (SIN)

TY3261

Technical Data

Approvals

UL and ULC Listed

Maximum Working Pressure

175 psi (12,1 bar)

Discharge Coefficient

K=5.6 gpm/psi^{1/2} (80,6 lpm/bar^{1/2})

Temperature Rating

162°F (72°C)

Vertical Adjustment

3/8 inch (9,5 mm)

Finishes

Sprinkler and Escutcheon:
Signal White or Chrome

Physical Characteristics

Body	Copper Alloy
Deflector	Copper
Valve Cap	Copper Alloy
Orifice Seal	PTFE
Heat Collectors	Copper

Operation

The sprinkler assembly contains a small fusible solder element. When exposed to sufficient heat from a fire, the solder melts and enables the internal components of the sprinkler to fall away. At this point the sprinkler activates with the deflector dropping into its operated position (Ref. Figure 1C), permitting water to flow.



Design Criteria

TYCO Model TY-QRF 5.6K Quick Response, Standard Coverage, Flush Pendent Sprinklers are intended for fire protection systems designed in accordance with the standard installation rules recognized by the applicable listing or approval agency (e.g., UL Listing is based on NFPA 13 requirements).

Precautionary Warnings for Corrosive Environments

The Model TY-QRF Flush Pendent Sprinklers must be installed in a non-corrosive environment. The improper use of corrosive agents such as flux, other products that contain chloride ions described, whether applied internally or externally to the sprinkler system, may result in corrosion of the sprinkler head, or stress corrosion cracking, which in turn may cause the sprinklers heads to develop leaks, operate unexpectedly, or not operate properly.

Accordingly, it is essential that the Model TY-QRF Flush Pendent Sprinklers be installed only by experienced fire sprinkler engineers, who comply fully with NFPA 13 and 25, ASTM B813, ASTM B828 and Copper Development Association (CDA).

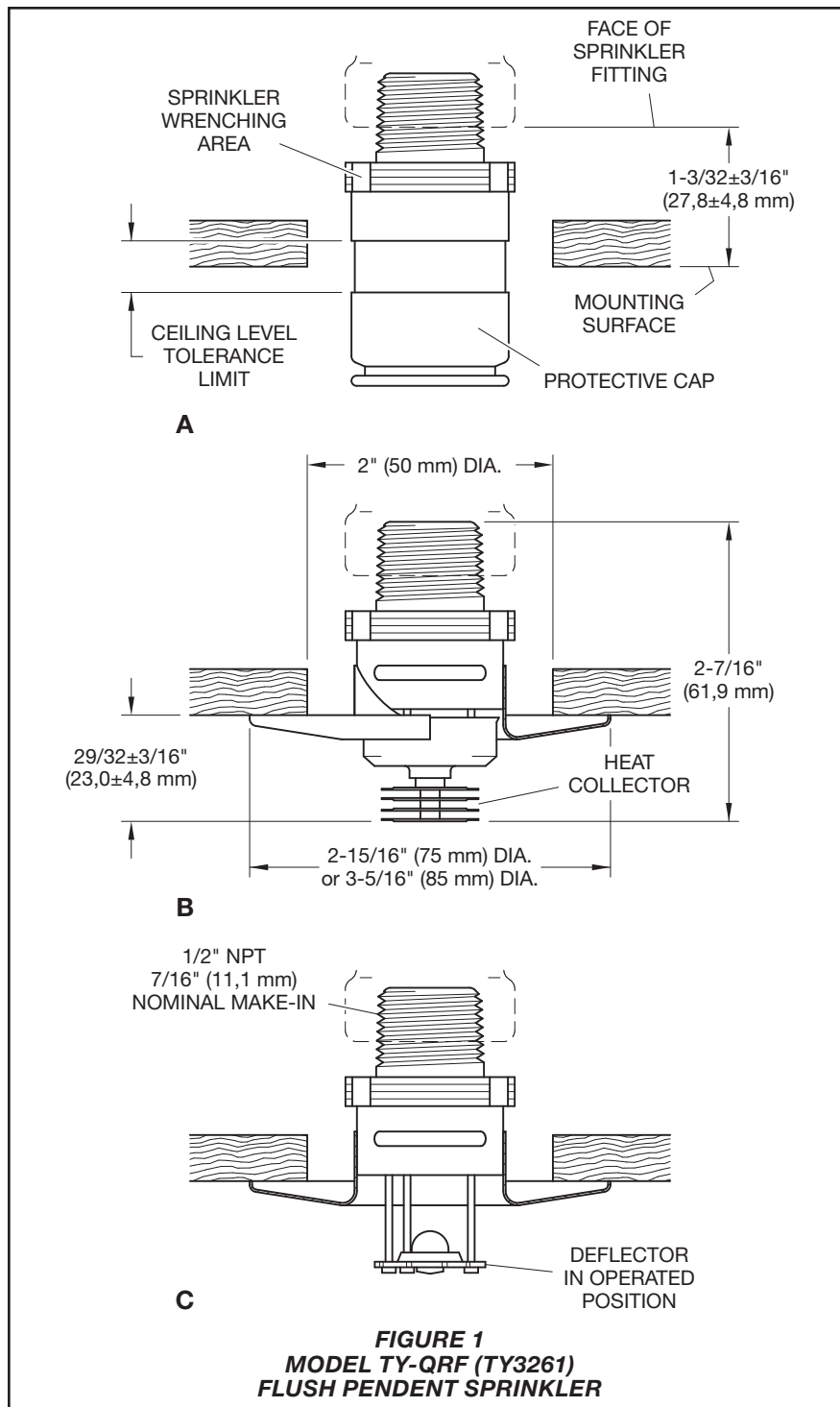

Copper Sprinkler System Piping
 Any time copper piping is used in any part of a fire sprinkler system, the copper piping must be installed in conformance with all applicable standards and requirements for copper piping, including: NFPA 13 and 25, ASTM B813, ASTM B828, and Copper Development Association (CDA). Any soldering in any part of a sprinkler system, either internally or externally, must be done with use of only an ASTM B 813

approved flux. Residual flux must be thoroughly removed from both the interior and exterior surfaces of the piping before installing the sprinkler heads. The use of improper flux, or the failure to thoroughly remove proper flux, may result in corrosion of the sprinkler head or stress cracking, which in turn may cause the sprinklers heads to develop leaks, operate unexpectedly, or not operate properly.

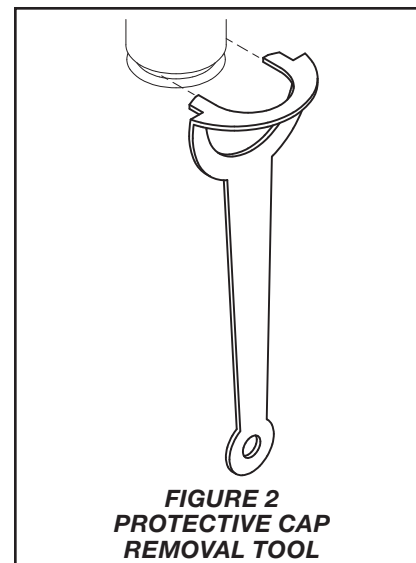

Installation

TYCO Model TY-QRF 5.6K Quick Response, Standard Coverage, Flush Pendent Sprinklers must be installed in accordance with this section.

General Instructions

The Protective Cap is to remain on the sprinkler during installation until the ceiling installation is complete. The Protective Cap must be removed to place the sprinkler in service.

A leak-tight 1/2 inch NPT sprinkler joint should be obtained by applying a minimum-to-maximum torque of 7 to 14 lbs.-ft. (9,5 to 19,0 Nm). Higher levels of torque can distort the sprinkler inlet with consequent leakage or impairment of the sprinkler.

Do not attempt to compensate for insufficient adjustment in an Escutcheon Plate by under- or over-tightening the sprinkler. Re-adjust the position of the sprinkler fitting to suit.

Each sprinkler must be inspected before installation. Do not use any sprinkler that exhibits any deformations or cracks, including cracks on the protective cap.

Step 1. The sprinkler must be installed only in the pendent position and with the sprinkler waterway centerline perpendicular to the mounting surface.

Step 2. Install the sprinkler fitting so that the distance from the face of the fitting to the mounting surface will be nominally 1-3/32 inches (27,8 mm) as shown in Figure 1A.

Step 3. With pipe thread sealant applied to the pipe threads, hand tighten the Sprinkler into the sprinkler fitting.

Step 4. Wrench-tighten the sprinkler using only the Sprinkler Socket or Wrench & Socket Combination (Ref. Figure 3). The wrench recess of the Socket is to be applied to the sprinkler wrenching area (Ref. Figure 1A).

Step 5. Use the Ceiling Level Tolerance Limit indicator on the Protective Cap to check for proper installation height. Relocate the sprinkler fitting as necessary. If desired the Protective Cap may also be used to locate the center of the clearance hole by gently pushing the ceiling material against the center point of the Cap.

Step 6. After the ceiling has been completed with the 2 inch (50 mm) diameter clearance hole, use the Protective Cap Removal Tool (Ref. Figure 2) to remove the Protective Cap and then push on the escutcheon until its flange just comes in contact with the ceiling. Do not continue to push the escutcheon such that it lifts a ceiling panel out of its normal position. If the escutcheon cannot be engaged with the sprinkler, or the escutcheon cannot be engaged sufficiently to contact the ceiling, relocate the sprinkler fitting as necessary.

Care and Maintenance

TYCO Model TY-QRF 5.6K Quick Response, Standard Coverage, Flush Pendent Sprinklers must be maintained and serviced in accordance with this section.

Before closing a fire protection system main control valve for maintenance work on the fire protection system that it controls, permission to shut down the affected fire protection system must be obtained from the proper authorities and all personnel who may be affected by this action must be notified.

Absence of an Escutcheon Plate may delay the time to sprinkler operation in a fire situation.

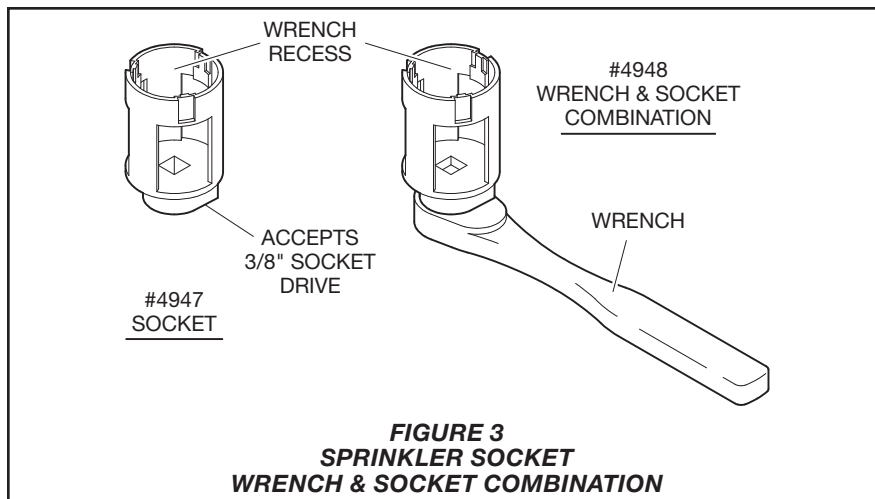

Sprinklers which are found to be leaking or exhibiting visible signs of corrosion must be replaced.

Automatic sprinklers must never be painted, plated, coated, or otherwise altered after leaving the factory. Modified or over heated sprinklers must be replaced.

Care must be exercised to avoid damage before, during, and after installation. Sprinklers damaged by dropping, striking, wrench twist/slippage, or the like, must be replaced.

The owner is responsible for the inspection, testing, and maintenance of their fire protection system and devices in compliance with this document, as well as with the applicable standards of the National Fire Protection Association (e.g., NFPA 25), in addition to the standards of any other authorities having jurisdiction. Contact the installing contractor or product manufacturer with any questions.

It is recommended that automatic sprinkler systems be inspected, tested, and maintained by a qualified Inspection Service in accordance with local requirements and/or national codes.

Limited Warranty

For warranty terms and conditions, visit www.tyco-fire.com.

Ordering Procedure

Contact your local distributor for availability. When placing an order, indicate the full product name and part number (P/N).

Sprinkler Assemblies

Specify: Model TY-QRF (TY3261) 5.6K Flush Pendent Sprinkler without Escutcheon, (specify) finish, P/N (specify):

Signal White (RAL9003). 53-261-4-162
Chrome. 53-261-9-162

Escutcheons

Escutcheon ordered separately from Sprinkler Assembly. See Sprinkler Assembly for ordering information.

Specify: Escutcheon for Model TY-QRF (TY3261) 5.6K Flush Pendent Sprinkler, (specify) finish, P/N (specify):

75 mm Outside Diameter
Signal White (RAL9003). 56-123-4-001
Chrome. 56-123-9-001

85 mm Outside Diameter
Signal White (RAL9003). 56-123-4-001T
Chrome. 56-123-9-001T

Accessories

Socket for Model TY-QRF Flush Pendent Sprinkler, P/N 56-000-4-947

Wrench & Socket for Model TY-QRF Flush Pendent Sprinkler, P/N 56-000-4-948

Protective Cap Removal Tool for Model TY-QRF Flush Pendent Sprinkler, P/N 56-000-4-300

