

## Series LFII Residential Sprinklers 6.9 K-factor Pendent/Recessed Pendent/Concealed NFPA 13 Optimized Wet Pipe Systems

### IMPORTANT

Refer to Technical Data Sheet TFP2300 for warnings pertaining to regulatory and health information.

Always refer to Technical Data Sheet TFP700 for the "INSTALLER WARNING" that provides cautions with respect to handling and installation of sprinkler systems and components. Improper handling and installation can permanently damage a sprinkler system or its components and cause the sprinkler to fail to operate in a fire situation or cause it to operate prematurely.

Scan the QR code or enter the URL in a web browser to access the most up-to-date electronic version of this document. Data rates may apply.



[docs.jci.com/tycofire/TFP408](http://docs.jci.com/tycofire/TFP408)

## General Description

The TYCO Series LFII Residential Pendent, Recessed Pendent, and Concealed Pendent Sprinklers (TY4234) are decorative, fast response, frangible bulb sprinklers designed for use in residential occupancies such as homes, apartments, dormitories, and hotels. When enhanced flow characteristics for residential portions of any occupancy per NFPA 13 is the major consideration, the Series LFII (TY4234) should be the first choice.

When higher flow demands are required for residential sprinklers used in an NFPA 13 design, the large 6.9 K-factor of the Series LFII (TY4234) is an attractive choice. Although mostly intended where residential sprinklers are to be used in an NFPA 13 design, the Series LFII (TY4234) can also be used in wet pipe residential sprinkler systems for one- and two-family dwellings and mobile homes per NFPA 13D, and wet pipe residential sprinkler systems for residential occupancies up to and including four stories in height per NFPA 13R.

The recessed version of the sprinkler is intended for use in areas with finished ceilings. It employs a two-piece Style 30 Recessed Escutcheon. The Recessed Escutcheon provides 1/4 in. (6,4 mm) of recessed adjustment or up to 1/2 in. (12,7 mm) of total adjustment from the flush mounting surface position. The adjustment provided by the Recessed Escutcheon or Concealed Cover Plate provides a measure of flexibility with regard to which the length of fixed pipe drops to the sprinklers must be cut.

The concealed version utilizes a cover plate assembly that conceals the sprinkler operating components above the ceiling. The separable two-piece design of the Cover Plate and Support Cup Assemblies allows installation of the sprinklers and pressure testing of the fire protection system prior to the installation of the ceiling or application of a finish coating.

Also, the separable "push-on and thread-off" two-piece design of the concealed version provides for 1/2 in. (12,7 mm) of vertical adjustment.

The Series LFII Residential Pendent, Recessed Pendent, and Concealed Pendent Sprinklers have been designed with heat sensitivity and water distribution characteristics proven to help in the control of residential fires and to improve the chance for occupants to escape or be evacuated.

The Series LFII Residential Concealed Pendent Sprinklers (TY4234) are shipped with a Disposable Protective Cap. The Protective Cap is temporarily removed for installation, and it must be replaced to protect the sprinkler



while the ceiling is being installed or finished. The tip of the Protective Cap can also be used to mark the center of the ceiling hole into plaster board, ceiling tiles, etc. by gently pushing the ceiling product against the Protective Cap. When ceiling installation is complete, the Protective Cap must be removed and the Cover Plate Assembly installed. The Protective Cap must be removed to ensure proper performance of the sprinklers.

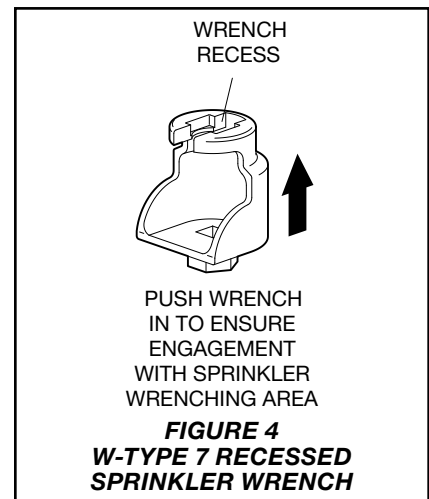
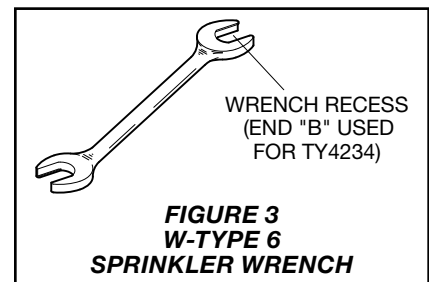
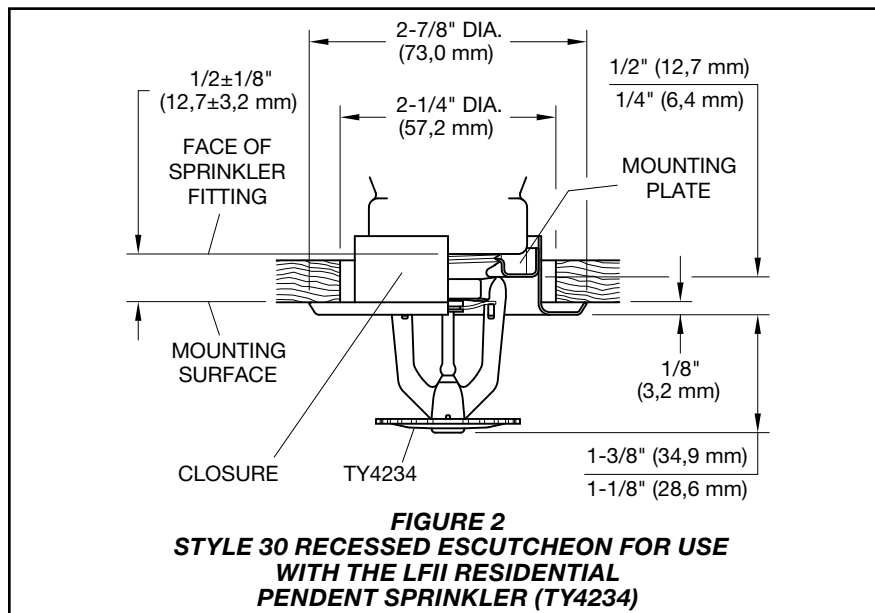
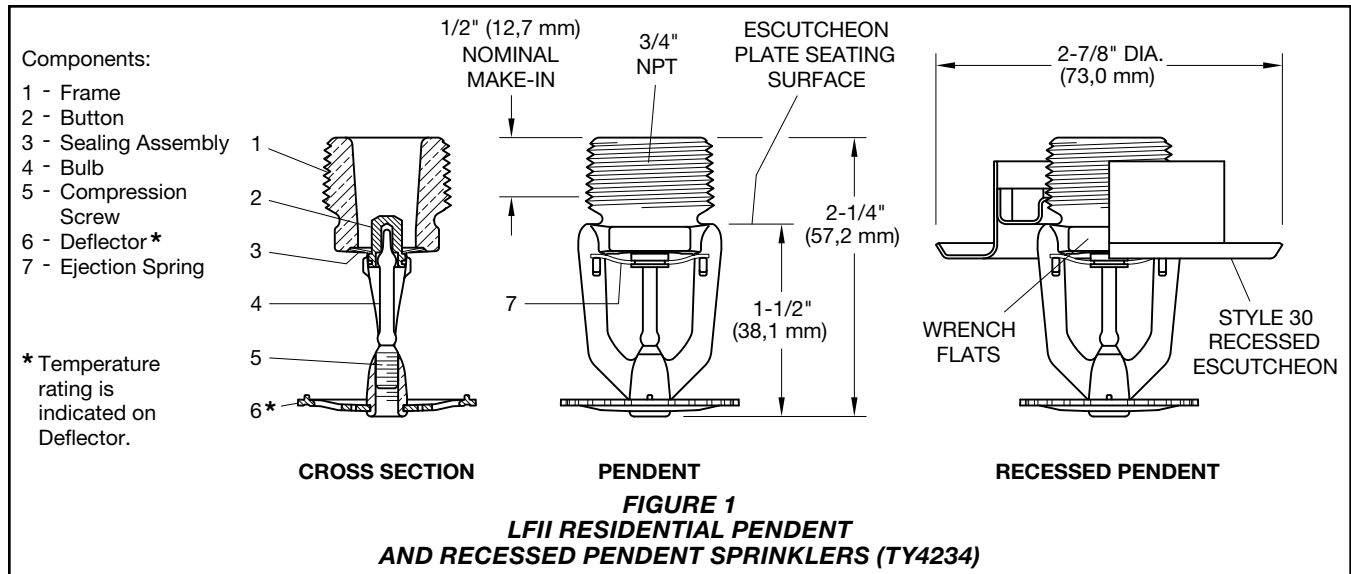

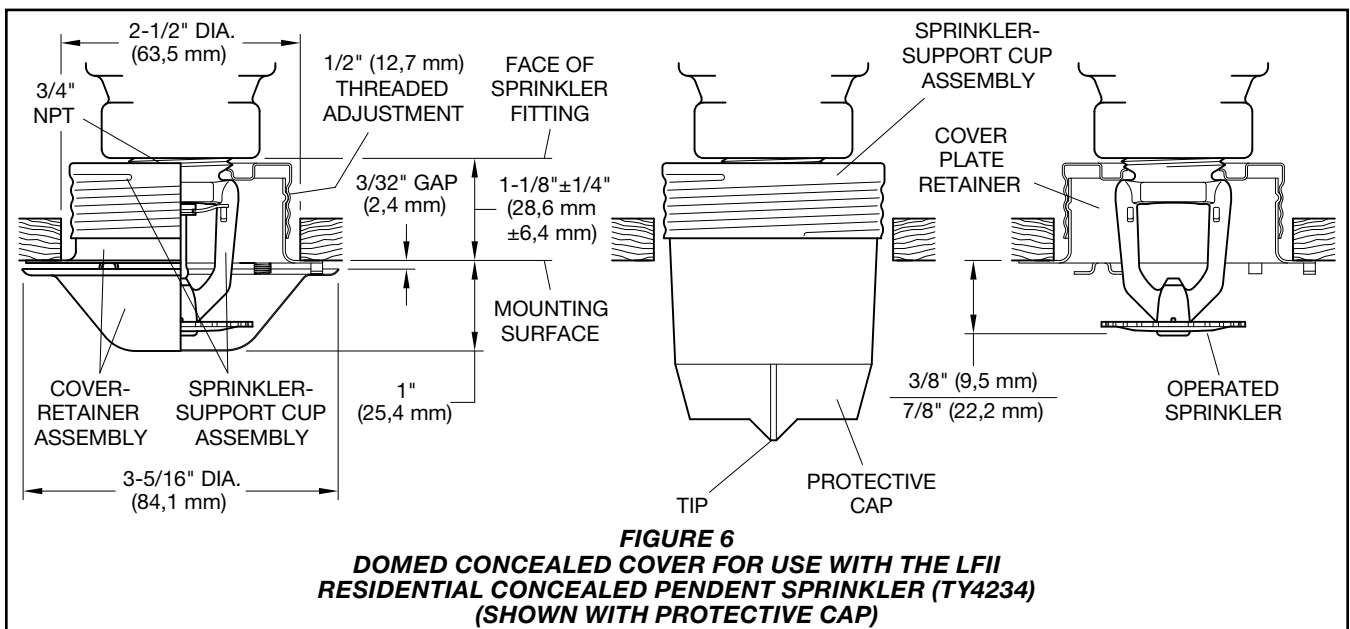
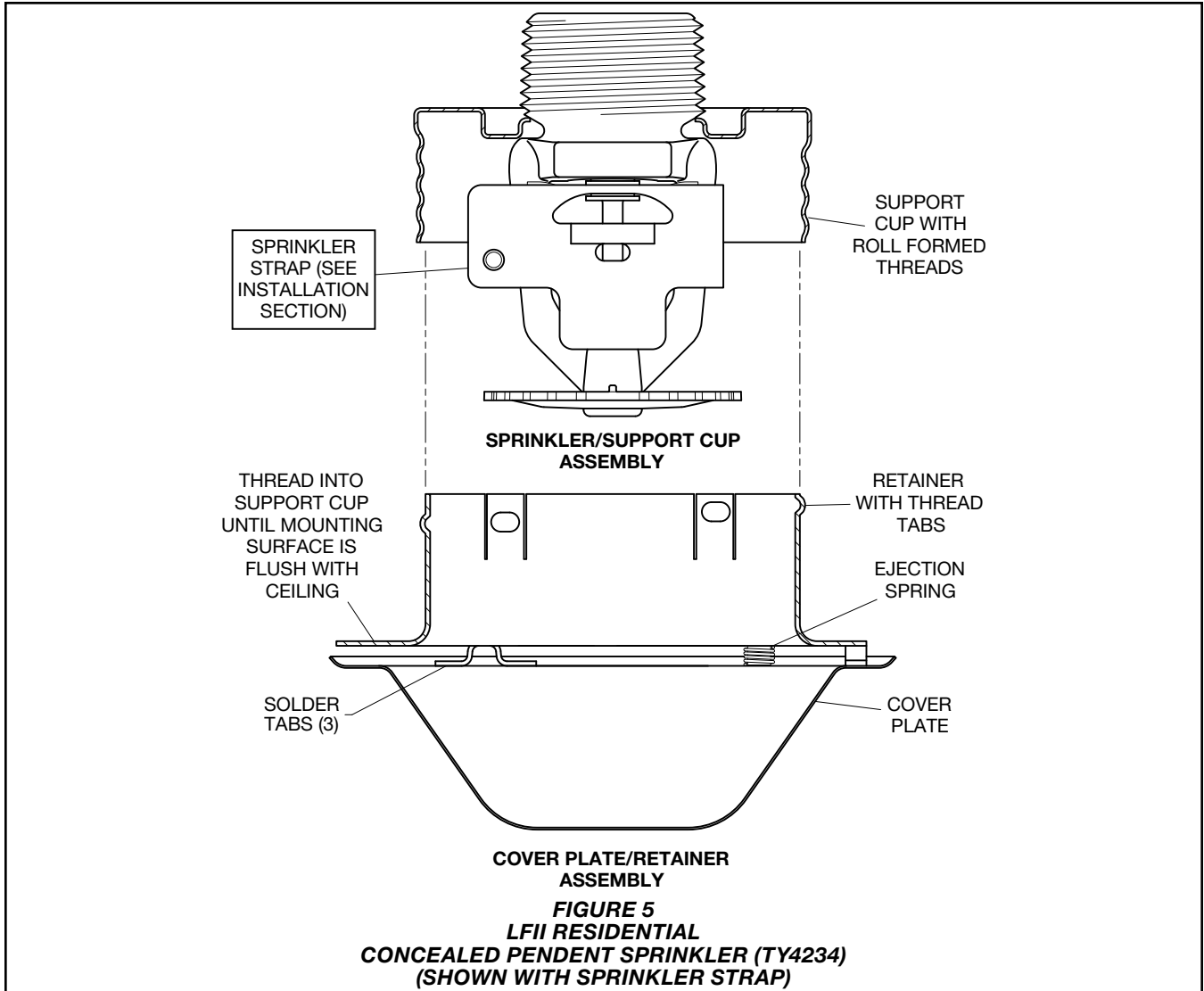

Max. Coverage Area (a) ft x ft. (m x m)	Maximum Spacing ft (m)	WET PIPE SYSTEM Minimum Flow and Residual Pressure <sup>(b, c)</sup>						
		Pendent and Recessed Pendent				Deflector to Ceiling	Installation Type	Minimum Spacing ft (m)
		Ordinary Temp. Rating 155°F (68°C)		Intermediate Temp. Rating 175°F (79°C)				
		Flow GPM (L/min)	Pressure PSI (bar)	Flow GPM (L/min)	Pressure PSI (bar)			
12 x 12 (3,7 x 3,7)	12 (3,7)	19 (71,9)	7.6 (0,52)	19 (71,9)	7.6 (0,52)	Smooth Ceilings 1-1/4 to 4 in.  Beamed Ceilings per NFPA 13D, 13R, or 13 Pendent and Recessed Pendent 1-1/4 to 1-3/4 in. below bottom of beam.	Recessed using Style 30 Escutcheon or non-recessed per NFPA 13D, 13R, or 13	8 (2,4)
14 x 14 (4,3 x 4,3)	14 (4,3)	19 (71,9)	7.6 (0,52)	19 (71,9)	7.6 (0,52)			
16 x 16 (4,9 x 4,9)	16 (4,9)	19 (71,9)	7.6 (0,52)	19 (71,9)	7.6 (0,52)			
18 x 18 (5,5 x 5,5)	18 (5,5)	19 (71,9)	7.6 (0,52)	19 (71,9)	7.6 (0,52)			
20 x 20 (6,1 x 6,1)	20 (6,1)	22 (83,3)	10,2 (0,70)	22 (83,3)	10,2 (0,70)			

**Notes:**

- a. For coverage area dimensions less than or between those indicated, use the minimum required flow for the next highest coverage area for which hydraulic design criteria are stated.
- b. Requirement is based on minimum flow in GPM (LPM) from each sprinkler. The associated residual pressures are calculated using the nominal K-factor. See Hydraulic Design under the Design Criteria section.
- c. For NFPA 13 residential applications, the greater of 0.1 gpm/ft<sup>2</sup> over the design area or the flow in accordance with the criteria in this table must be used.

**TABLE A**  
**WET PIPE SYSTEM**  
**SERIES LFII RESIDENTIAL PENDENT AND RECESSED PENDENT SPRINKLERS (TY4234)**  
**NFPA 13D, 13R AND 13 HYDRAULIC DESIGN CRITERIA**

Corrosion-resistant coatings, where applicable, are utilized to extend the life of copper alloy sprinklers beyond that which would otherwise be obtained when exposed to corrosive atmospheres. Although corrosion-resistant coated sprinklers have passed the standard corrosion tests of the applicable Approval agencies, the testing is not representative of all possible corrosive atmospheres. Consequently, it is recommended that the end user be consulted with respect to the suitability of these coatings for any given corrosive environment. The effects of ambient temperature, concentration of chemicals, and gas/chemical velocity should be considered, as a minimum, along with the corrosive nature of the chemical to which the sprinklers will be exposed.

**NOTICE**

*The Series LFII (TY4234) Residential Pendent, Recessed Pendent, and Concealed Pendent Sprinklers described herein must be installed and maintained in compliance with this document and with the applicable standards of the NATIONAL FIRE PROTECTION ASSOCIATION (NFPA), in addition to the standards of any authorities having jurisdiction. Failure to do so may impair the performance of these devices.*

*The owner is responsible for maintaining their fire protection system and devices in proper operating condition. Contact the installing contractor or product manufacturer with any questions.*

**Sprinkler Identification Number (SIN)**

TY4234

**Technical Data**

**Approvals**

UL and C-UL Listed

Certified to all requirements of NSF/ANSI 61

NYC Approved under MEA 44-03-E-2  
FM Approved (Pendent and Recessed Pendent Only)

The Series LFII Concealed Pendent Sprinklers are only listed and approved with the Series LFII Concealed Cover Plates having a factory applied finish.

**Note:** Sprinklers with a polyester finish are UL Listed as corrosion-resistant sprinklers.

See the Design Criteria section for details on these approvals.

**Maximum Working Pressure**

175 psi (12,1 bar)

**Discharge Coefficient**

K=6.9 GPM/psi<sup>1/2</sup> (99,4 LPM/bar<sup>1/2</sup>)

**Pipe Thread Connection:**

3/4 NPT

Max. Coverage Area (a) ft x ft (m x m)	Maximum Spacing ft (m)	WET PIPE SYSTEM Minimum Flow and Residual Pressure <sup>(b, c)</sup>						Deflector to Ceiling	Installation Type	Minimum Spacing ft (m)	
		Concealed Pendent				Smooth Ceilings 3/8 to 7/8 in.	Concealed				8 (2,4)
		Ordinary Temp. Rating 155°F (68°C)		Intermediate Temp. Rating 175°F (79°C)							
		Flow GPM (L/min)	Pressure PSI (bar)	Flow GPM (L/min)	Pressure PSI (bar)						
12 x 12 (3,7 x 3,7)	12 (3,7)	19 (71,9)	7.6 (0,52)	19 (71,9)	7.6 (0,52)	Smooth Ceilings 3/8 to 7/8 in.  Beamed Ceilings per NFPA 13D, 13R, or 13 installed in beam 3/8 to 7/8 in. below bottom of beam	Concealed	8 (2,4)			
14 x 14 (4,3 x 4,3)	14 (4,3)	19 (71,9)	7.6 (0,52)	19 (71,9)	7.6 (0,52)						
16 x 16 (4,9 x 4,9)	16 (4,9)	19 (71,9)	7.6 (0,52)	19 (71,9)	7.6 (0,52)						
18 x 18 (5,5 x 5,5)	18 (5,5)	21 (79,5)	9.3 (0,64)	21 (79,5)	9.3 (0,64)						
20 x 20 (6,1 x 6,1)	20 (6,1)	24 (90,8)	12.1 (0,83)	24 (90,8)	12.1 (0,83)						

**Notes:**  
a. For coverage area dimensions less than or between those indicated, use the minimum required flow for the next highest coverage area for which hydraulic design criteria are stated.  
b. Requirement is based on minimum flow in GPM (LPM) from each sprinkler. The associated residual pressures are calculated using the nominal K-factor. See Hydraulic Design under the Design Criteria section.  
c. For NFPA 13 residential applications, the greater of 0.1 gpm/ft<sup>2</sup> over the design area or the flow in accordance with the criteria in this table must be used.

**TABLE B**  
**WET PIPE SYSTEM**  
**SERIES LFII RESIDENTIAL CONCEALED PENDENT SPRINKLERS (TY4234)**  
**NFPA 13D, 13R AND 13 HYDRAULIC DESIGN CRITERIA**

**Sprinkler Temperature Rating**

Pendent and Recessed Pendent:  
155°F (68°C) or 175°F (79°C)

Concealed Pendent:

155°F (68°C) w/139°F (59°C) Cover Plate\*  
175°F (79°C) w/139°F (59°C) Cover Plate\*

\*Suitable for use with maximum  
100°F (38°C) ceiling temperature.

**Finishes**

- Sprinkler:  
Natural Brass, Pure White Polyester Coated, Signal White Polyester Coated, or Chrome Plated
- Recessed Escutcheon:  
Brass, Pure White Polyester Coated, Signal White Polyester Coated, or Chrome
- Concealed Cover Plate:  
Refer to Ordering Procedure section.

**Physical Characteristics**

Frame .....	Brass
Button .....	Copper
Sealing Assembly ..	Beryllium Nickel w/TEFLON
Bulb .....	3 mm Glass
Compression Screw ..	Bronze
Deflector .....	Bronze
Ejection Spring .....	Stainless Steel
Support Cup .....	Steel
Cover Plate .....	Brass
Retainer .....	Brass
Cover Plate Ejection Spring	Stainless Steel

**Operation**

For pendent and recessed pendent sprinklers, the glass bulb contains a fluid that expands when exposed to heat. When the rated temperature is reached, the fluid expands sufficiently to shatter the glass bulb allowing the sprinkler to activate and flow water.

For the concealed pendent sprinkler, the cover plate which is soldered to the support cup at three places, first falls away when exposed to heat from a fire. The sprinkler then operates similar to pendent and recessed pendent sprinklers described above.

**Design Criteria**

**UL AND C-UL LISTING CRITERIA**

The TYCO Series LFII Residential Pendent, Recessed Pendent, and Concealed Pendent Sprinklers (TY4234) are UL and C-UL Listed for installation in accordance with the following criteria.

**Residential Sprinkler Design Guide**

When conditions exist that are outside the scope of the provided criteria, refer to the Residential Sprinkler Design Guide TFP490 for the manufacturer's recommendations that may be acceptable to the local authority having jurisdiction.

**System Type**

Only wet pipe systems may be utilized.

**Ceiling Types**

Smooth flat horizontal, or beamed, or sloped, in accordance with the 2013 Edition of NFPA 13D, 13R, or 13 as applicable.

**Hydraulic Design (NFPA 13D and 13R)**

The minimum required sprinkler flow rate for systems designed to NFPA 13D or NFPA 13R are given in Tables A and B as a function of temperature rating and the maximum allowable coverage areas. The sprinkler flow rate is the minimum required discharge from each of the total number of "design sprinklers" as specified in NFPA 13D or NFPA 13R.

Max. Coverage Area <sup>(a)</sup> ft x ft (m x m)	Maximum Spacing ft (m)	WET PIPE SYSTEM Minimum Flow and Residual Pressure <sup>(b, c)</sup>						
		Ordinary Temp. Rating 155°F (68°C)		Intermediate Temp. Rating 175°F (79°C)		Deflector to Ceiling	Installation Type	Minimum Spacing ft (m)
		Flow GPM (L/min)	Pressure PSI (bar)	Flow GPM (L/min)	Pressure PSI (bar)			
12 x 12 (3,7 x 3,7)	12 (3,7)	20 (75,7)	8.4 (0,58)	20 (75,7)	8.4 (0,58)	Smooth Ceilings 1-1/4 to 4 in.  Beamed Ceilings 1-1/4 to 1-3/4 in. below bottom of beam.	Recessed using Style 30 Escutcheon or non-recessed	8 (2,4)
14 x 14 (4,3 x 4,3)	14 (4,3)	20 (75,7)	8.4 (0,58)	20 (75,7)	8.4 (0,58)			
16 x 16 (4,9 x 4,9)	16 (4,9)	20 (75,7)	8.4 (0,58)	20 (75,7)	8.4 (0,58)			
18 x 18 (5,5 x 5,5)	18 (5,5)	20 (75,7)	8.4 (0,58)	20 (75,7)	8.4 (0,58)			
20 x 20 (6,1 x 6,1)	20 (6,1)	23 (87,1)	11.1 (0,76)	23 (87,1)	11.1 (0,76)			

**Notes:**

- a. For coverage area dimensions less than or between those indicated, use the minimum required flow for the next highest coverage area for which hydraulic design criteria are stated.
- b. Requirement is based on minimum flow in GPM (LPM) from each sprinkler. The associated residual pressures are calculated using the nominal K-factor. See Hydraulic Design under the Design Criteria section.
- c. For FM residential applications, the greater of 0.1 gpm/ft<sup>2</sup> over the design area (i.e., SxL) or the flow in accordance with the criteria in this table must be used.

**TABLE C**  
**FM APPROVAL**  
**WET PIPE SYSTEM**  
**SERIES LFII RESIDENTIAL PENDENT AND RECESSED PENDENT SPRINKLERS (TY4234)**  
**HYDRAULIC DESIGN CRITERIA**

**Hydraulic Design (NFPA 13)**

For systems designed to NFPA 13, the number of design sprinklers is to be the four most hydraulically demanding sprinklers. The minimum required discharge from each of the four sprinklers is to be the greater of the following:

- The flow rates given in Tables A and B for NFPA 13D and 13R as a function of temperature rating and the maximum allowable coverage area
- A minimum discharge of 0.1 gpm/ft<sup>2</sup> over the “design area” comprised of the four most hydraulically demanding sprinklers for the actual coverage areas being protected by the four sprinklers

Example No. 1: A corridor being protected is 8 ft. wide; consequently, an actual coverage area of 8 ft. x 20 ft. is being contemplated. Based on using the LFII (TY4234) Residential Pendent Sprinkler, the flow rate provided in Table A and B for a 20 ft x 20 ft coverage area is 22 GPM. However based on minimum discharge of 0.1 gpm/ft<sup>2</sup> the flow rate would be 16 GPM. In this case a minimum flow rate of 22 GPM for this design sprinkler must be utilized.

Example No. 2: A long narrow room being protected is 12 ft wide; consequently, an actual coverage area of 12 ft x 20 ft is being contemplated. Based

on using the LFII (TY4234) Residential Pendent Sprinkler, the flow rate provided in Table A for a 20 ft x 20 ft coverage area is 22 GPM. However based on minimum discharge of 0.1 gpm/ft<sup>2</sup> the flow rate would be 24 GPM. In this case a minimum flow rate of 24 GPM for this design sprinkler must be utilized.

**Obstruction to Water Distribution**

Sprinklers are to be located in accordance with the obstruction rules of NFPA 13D, 13R, and 13 as applicable for residential sprinklers as well as with the obstruction criteria described within the TYCO Technical Data Sheet TFP490.

**Operational Sensitivity**

Sprinklers are to be installed with a deflector-to-ceiling distance of 1-1/4 to 4 inches or in the recessed position using only the Style 30 escutcheon as shown in Figure 2.

For concealed pendent sprinkler installations, the sprinklers relative to the ceiling mounting surface are to be installed per Figure 6.

The concealed pendent sprinkler must not be used in applications where the air pressure above the ceiling is greater than that below. Down drafts through the Support Cup could delay sprinkler operation in a fire situation.

**Sprinkler Spacing**

The minimum spacing between sprinklers is 8 ft (2,4 m). The maximum spacing between sprinklers cannot exceed the length of the coverage area (See Tables A and B) being hydraulically calculated (for example, maximum 12 ft for a 12 ft x 12 ft coverage area, or 20 ft for a 20 ft x 20 ft coverage area).

**FM APPROVAL CRITERIA**

The Series LFII (TY4234) Residential Pendent and Recessed Pendent Sprinklers are FM Approved for installation in accordance with the applicable Factory Mutual Loss Prevention Data Sheet FM 2-5. Criteria provided by FM may differ from UL and/or NFPA, therefore the designer should review and become familiar with Factory Mutual requirements before proceeding with design.

The following information pertaining to System Type, Hydraulic Design, and Sprinkler spacing are provided for reference and are not intended to provide complete installation criteria as provided in the applicable Factory Mutual Loss Prevention Data Sheet.

**Residential Sprinkler Design Guide**

When conditions exist that are outside the scope of the provided criteria, refer to the Residential Sprinkler Design Guide TFP490 for the manufacturer’s recommendations that may be acceptable to the local authority having jurisdiction.

### System Type

Only wet pipe systems may be utilized.

### Hydraulic Design

The number of design sprinklers is to be the greater of the four most hydraulically demanding sprinklers, or 1500 sq. ft as per FM Data Sheet 2-5. The minimum required discharge from each of the four sprinklers is to be the greater of the following:

- The flow rates given in Table C as a function of the maximum allowable coverage area
- A minimum discharge of 0.1 gpm/ft<sup>2</sup> over the “design area” comprised of the four most hydraulically demanding sprinklers for the actual coverage areas being protected by the four sprinklers

Example No. 1: A corridor being protected is 10 ft wide; consequently, an actual coverage area of 10 ft x 20 ft is being contemplated. Based on using the LFII (TY4234) Residential Pendent Sprinkler, the flow rate provided in Table C for a 20 ft x 20 ft coverage area is 23 GPM. However, based on minimum discharge of 0.1 gpm/ft<sup>2</sup>, the flow rate would be 20 GPM. In this case, a minimum flow rate of 23 GPM for this design sprinkler must be utilized.

Example No. 2: A long narrow room being protected is 12 ft wide; consequently, an actual coverage area of 12 ft x 20 ft is being contemplated. Based on using the LFII (TY4234) Residential Pendent Sprinkler, the flow rate provided in Table C for a 20 ft x 20 ft coverage area is 23 GPM. However, based on minimum discharge of 0.1 gpm/ft<sup>2</sup>, the flow rate would be 24 GPM. In this case, a minimum flow rate of 24 GPM for this design sprinkler must be utilized. (In no case shall the design pressure be less than 7 psi.)

### Sprinkler Spacing

The minimum spacing between sprinklers is 8 ft (2,4 m). The maximum spacing between sprinklers cannot exceed the length of the coverage area (see Table C) being hydraulically calculated (for example, maximum 12 ft for a 12 ft x 12 ft coverage area, or 20 ft for a 20 ft x 20 ft coverage area).

## Installation

The TYCO Series LFII Residential Pendent, Recessed Pendent, and Concealed Pendent Sprinklers (TY4234) must be installed in accordance with this section.

### General Instructions

Do not install any bulb type sprinkler if the bulb is cracked or there is a loss of liquid from the bulb. With the

sprinkler held horizontally, a small air bubble should be present. The diameter of the air bubble is approximately 1/16 in.(1,6 mm).

A leak-tight 3/4 in. NPT sprinkler joint should be obtained by applying a minimum-to-maximum torque of 10 to 20 lb-ft (13,4 to 26,8 N·m). Higher levels of torque can distort the sprinkler inlet with consequent leakage or impairment of the sprinkler.

Do not attempt to compensate for insufficient adjustment in an Escutcheon Plate by under or over-tightening the Sprinkler. Re-adjust the position of the sprinkler fitting to suit.

### Series LFII Residential Pendent Sprinklers

The Series LFII Residential Pendent Sprinklers must be installed in accordance with the Steps 1P through 3P.

**Step 1P.** Install pendent sprinklers in the pendent position with the deflector parallel to the ceiling.

**Step 2P.** With pipe thread sealant applied to the pipe threads, hand-tighten the sprinkler into the sprinkler fitting.

The sprinkler has been provided with a Sprinkler Strap similar to that shown in Figure 5 for the concealed sprinkler assembly. Refer to NFPA 13 for guidance regarding removal of protective straps and caps. As long as the Sprinkler Strap remains in place, the system is considered to be “Out Of Service”.

**Step 3P.** Tighten the sprinkler into the sprinkler fitting using only the W-Type 6 Sprinkler Wrench (Figure 3). With reference to Figure 1, apply the W-Type 6 Sprinkler Wrench to the wrench flats.

Refer to Technical Data Sheet TFP700 regarding instructions for the removal of the Sprinkler Strap.

### Series LFII Residential Recessed Pendent Sprinklers

The Series LFII Residential Recessed Pendent Sprinklers must be installed in accordance with Steps 1R through 4R.

**Step 1R.** Install recessed pendent sprinklers in the pendent position with the deflector parallel to the ceiling.

**Step 2R.** After installing the Style 30 Mounting Plate over the sprinkler threads and with pipe thread sealant applied to the pipe threads, hand-tighten the sprinkler into the sprinkler fitting.

The recessed sprinkler has been provided with a Sprinkler Strap similar to that shown in Figure 5 for the concealed sprinkler assembly. Refer to NFPA 13 for guidance regarding removal of protective straps and caps.

As long as the Sprinkler Strap remains in place, the system is considered to be “Out Of Service”.

**Step 3R.** Tighten the sprinkler into the sprinkler fitting using only the W-Type 7 Recessed Sprinkler Wrench (Figure 4). With reference to Figure 1, apply the W-Type 7 Recessed Sprinkler Wrench to the sprinkler wrench flats.

**Step 4R.** After the ceiling has been installed or the finish coat has been applied, slide on the Style 30 Closure over the Series LFII Sprinkler and push the Closure over the Mounting Plate until its flange comes in contact with the ceiling.

Refer to Technical Data Sheet TFP700 regarding instructions for the removal of the Sprinkler Strap.

### Series LFII Residential Concealed Pendent Sprinklers

The Series LFII Residential Concealed Pendent Sprinklers must be installed in accordance with Steps 1C through 6C.

**Step 1C.** Install the sprinkler in the pendent position and with the centerline of the sprinkler perpendicular to the mounting surface.

**Step 2C.** Remove the Protective Cap. Refer to NFPA 13 for guidance regarding removal of protective straps and caps

**Step 3C.** With pipe thread sealant applied to the pipe threads, and using the W-Type 7 Wrench shown in Figure 4, install and tighten the Sprinkler/Support Cup Assembly into the fitting. The W-Type 7 Wrench will accept a 1/2 in. ratchet drive.

**Step 4C.** Replace the Protective Cap by pushing it upwards until it bottoms out against the Support Cup. The Protective Cap helps prevent damage to the Deflector and Arms during ceiling installation and/or during application of the finish coating of the ceiling. It may also be used to locate the center of the clearance hole by gently pushing the ceiling material against the center point of the Cap.

As long as the Sprinkler Strap (Figure 5) or the Protective Cap (Figure 6) remains in place, the system is considered to be “Out Of Service”.

**Step 5C.** After the ceiling has been completed with the 2-1/2 in. (63 mm) diameter clearance hole and in preparation for installing the Cover Plate/Retainer Assembly, remove and discard the Protective Cap and the Sprinkler Strap.

Refer to Technical Data Sheet TFP700 regarding instructions for the removal of the Sprinkler Strap.

**Step 6C.** Push the Cover Plate/Retainer Assembly into the Support Cup, and as necessary, make the final adjustment of the Cover Plate with respect to the ceiling by turning the Cover Plate/Retainer Assembly clockwise until its flange just comes in contact with the ceiling.

If it becomes necessary to remove the Cover Plate, it can be removed by unscrewing in a counter-clockwise direction.

If the Cover Plate/Retainer Assembly cannot be engaged with the Support Cup or the Cover Plate/Retainer Assembly cannot be engaged sufficiently to contact the ceiling, the Sprinkler Fitting must be repositioned.

## Care and Maintenance

The TYCO Series LFII Residential Pendent, Recessed Pendent, and Concealed Pendent Sprinklers (TY4234) must be maintained and serviced in accordance with this section.

Before closing a fire protection system main control valve for maintenance work on the fire protection system that it controls, obtain permission to shut down the affected fire protection system from the proper authorities and notify all personnel who may be affected by this action.

Absence of a Cover Plate can delay the sprinkler operation in a fire situation.

The owner must assure that the sprinklers are not used for hanging any objects and that the sprinklers are only cleaned by means of gently dusting with a feather duster; otherwise, non-operation in the event of a fire or inadvertent operation may result.

When properly installed, there is a nominal 3/32 in. (2,4 mm) air gap between the lip of the Cover Plate and the ceiling, as shown in Figure 6. This air gap is necessary for proper operation of the sprinkler by allowing heat flow from a fire to pass below and above the Cover Plate to help assure appropriate release of the Cover Plate in a fire situation. If the ceiling needs repainting after sprinkler installation, exercise care to ensure that the new paint does not seal off any of the air gap. Failure to do so may impair sprinkler operation.

Factory painted Cover Plates must not be repainted. They should be replaced, if necessary, by factory painted units. Non-factory applied paint may

adversely delay or prevent sprinkler operation in the event of a fire.

Do not pull the Cover Plate relative to the Retainer. Separation may result.

Sprinklers which are found to be leaking or exhibiting visible signs of corrosion must be replaced.

Automatic sprinklers must never be painted, plated, coated, or otherwise altered after leaving the factory. Modified sprinklers must be replaced. Sprinklers that have been exposed to corrosive products of combustion, but have not operated, should be replaced if they cannot be completely cleaned by wiping the sprinkler with a cloth or by brushing it with a soft bristle brush.

Care must be exercised to avoid damage to the sprinklers - before, during, and after installation. Sprinklers damaged by dropping, striking, wrench twist/slippage, or the like, must be replaced. Also, replace any sprinkler that has a cracked bulb or that has lost liquid from its bulb. Refer to the installation section for additional information.

The owner is responsible for the inspection, testing, and maintenance of their fire protection system and devices in compliance with this document, as well as with the applicable standards of the NATIONAL FIRE PROTECTION ASSOCIATION, for example NFPA 25, in addition to the standards of any other authorities having jurisdiction. Contact the installing contractor or product manufacturer with any questions.

Automatic sprinkler systems are recommended to be inspected, tested, and maintained by a qualified Inspection Service in accordance with local requirements and/or national codes.

## Limited Warranty

For warranty terms and conditions, visit [www.tyco-fire.com](http://www.tyco-fire.com).

## Ordering Procedure

Contact your local distributor for availability. When placing an order, indicate the full product name and Part Number (P/N).

- For pendent sprinkler, order pendent sprinkler assembly plus sprinkler wrench.
- For recessed pendent sprinkler, order pendent sprinkler assembly plus separately ordered recessed escutcheon plus sprinkler wrench.

- For concealed pendent sprinkler, order concealed pendent sprinkler assembly plus separately ordered cover plate assembly plus sprinkler wrench.

### Pendent Sprinkler Assembly

Specify: Series LFII (TY4234), K=6.9, Residential Pendent Sprinkler, (specify) temperature rating, (specify) finish, P/N (specify):

#### 155 °F (68 °C)

Natural Brass	51-069-1-155
Pure White (RAL9010)	
Polyester <sup>1,2</sup>	51-069-3-155
Signal White (RAL9003)	
Polyester <sup>1</sup>	51-069-4-155
Chrome Plated	51-069-9-155

#### 175 °F (79 °C)

Natural Brass	51-069-1-175
Pure White (RAL9010)	
Polyester <sup>1,2</sup>	51-069-3-175
Signal White (RAL9003)	
Polyester <sup>1</sup>	51-069-4-175
Chrome Plated	51-069-9-175

1. UL Listed as corrosion-resistant.
2. Eastern Hemisphere sales only.

### Concealed Pendent Sprinkler Assembly

Specify: Series LFII (TY4234), K=6.9, Residential Concealed Pendent Sprinkler, (specify) temperature rating without Cover Plate Assembly, P/N (specify):

155°F (68 °C)	51-068-1-155
175°F (79 °C)	51-068-1-175

### Separately Ordered Recessed Escutcheon

Specify: Style 30 Recessed Escutcheon with (specify\*) finish, P/N (specify\*)

\*Refer to Technical Data Sheet TFP770

### Separately Ordered Cover Plate Assembly

Specify: 139°F (58°C), Cover Plate Assembly having a (specify) finish for the Series LFII (TY4234), K=6.9, Residential Concealed Pendent Sprinkler, P/N (specify):

Pure White (RAL 9010)	
Polyester <sup>1</sup>	56-873-3-135
Signal White (RAL 9003)	
Polyester	56-873-4-135
Chrome	56-873-9-135
Custom	56-873-X-135

1. Eastern Hemisphere sales only.

### Separately Ordered Sprinkler Wrench

Specify: W-Type 6 Sprinkler Wrench, P/N 56-000-6-387 (For pendent sprinklers)

Specify: W-Type 7 Sprinkler Wrench, P/N 56-850-4-001 (For recessed pendent sprinklers and concealed pendent sprinklers)





## TFP408 Change History Appendix

ISSUE DATE	NOTES
08-22	Page 1, updated QR code and URL; Page 8, changed corporate address and telephone number to 1467 Elmwood Avenue, Cranston, RI 02910   Telephone +1-401-781-8220, formerly 1400 Pennbrook Parkway, Lansdale, PA 19446   Telephone +1-215-362-0700.
03-22	Removed RAPID RESPONSE branding throughout; Page 1, added QR code and URL to allow convenient access to electronic version from printed document.
12-18	Added note indicating sprinklers with polyester finish are UL Listed as corrosion resistant sprinklers.
08-18	Updated Tyco® branding and document format; Added Johnson Controls copyright; Added disclaimer stating specifications and information subject to change without notice; Added reference to Regulatory and Health Warning Technical Data Sheet TFP2300.
09-16	Remove Grey White (RAL9002) Cover Plate Assembly finish, no longer offered.
01-16	Added NSF/ANSI 61 certification mark.
04-13	Updated and standardized RAL color finishes; Removed sloped and beamed ceiling design criteria in accordance with UL; Added Certified to NSF/ANSI 61.
04-12	Clarified allowance for use of horizontal ceiling hydraulic design criteria for certain slope ceiling configurations in accordance with NFPA 13D 2010 Technical Interim Amendment (TIA) 1028R; Clarified dry pipe system application.
08-11	Added information for sloped ceiling installations based on NFPA 13D 2010 Technical Interim Amendment (TIA) 1028R; Updated references in Obstruction to Water Distribution section; Corrected SIN numbers in 2 Figure captions.
05-08	Changed Cover Plate Assembly Temperature Rating to 139°F (58°C), formerly shown as 135°F (57°C); Updated Cover Plate Assembly standard order finishes.
05-07	Add U.S. Patent No. 7,201,234.
02-07	Added FM installation criteria for Pendent and Recessed Pendent Sprinklers.
01-06	Added Rapid Response trademark.
03-05	Added all current sloped ceiling criteria.
10-04	New Technical Data Sheet TFP408 describes Series LFII Residential 6.9K Pendent, Recessed Pendent, and Concealed Pendent Sprinklers.