

Model F822 through F834 MULSIFYRE Directional Spray Nozzles, Open, High Velocity

IMPORTANT

Refer to Technical Data Sheet TFP2300 for warnings pertaining to regulatory and health information.

Always refer to Technical Data Sheet TFP700 for the "INSTALLER WARNING" that provides cautions with respect to handling and installation of sprinkler systems and components. Improper handling and installation can permanently damage a sprinkler system or its components and cause the sprinkler to fail to operate in a fire situation or cause it to operate prematurely.

Scan the QR code or enter the URL in a web browser to access the most up-to-date electronic version of this document. Data rates may apply.



docs.jci.com/tycofire/TFP810

General Description

The MULSIFYRE Nozzles are open (nonautomatic) nozzles and they are designed for use in water spray fixed systems for fire protection applications where a high velocity water application may be required. There are two configurations: the basic MULSIFYRE Nozzle shown in Figure 1 and the MULSIFYRE Nozzle with Model F880 Dust Cap shown in Figure 2. Each configuration is available in six different models that provide a wide range of orifice sizes and water distribution characteristics.

The MULSIFYRE Nozzles are internal scroll type nozzles and they discharge a uniformly filled cone of relatively high velocity water droplets. Although the MULSIFYRE Nozzles are designed primarily for use in fire extinguishment and control, they can also be used for exposure protection.

The MULSIFYRE Nozzles are typically used in water spray fixed systems for the protection of special hazards such as:

- oil filled transformers and switching equipment
- flammable liquid and gas storage tanks
- chemical process equipment
- conveyor systems
- openings in fire walls
- other equipment that is defined as hazardous due to the possibility of a rapidly spreading fire

MULSIFYRE Nozzles with Model F880 Dust Caps are used in applications where protection is required against insect infestation or accumulation of debris within the nozzle. The dust cap is designed for both indoor and outdoor use.

It is recommended that the end user be consulted with respect to the suitability of the materials of construction for any given corrosive environment. The effects of ambient temperature, concentration of chemicals, and gas/chemical velocity, should be considered, at a minimum, along with the corrosive nature to which the nozzles may be exposed.

The Model F822 through F834 MULSIFYRE Nozzles are a re-designation for the Gem Model F822 through F834.



NOTICE

The MULSIFYRE Nozzles described herein must be installed and maintained in compliance with this document, as well as with the applicable standards of the NATIONAL FIRE PROTECTION ASSOCIATION (NFPA), in addition to the standards of any other authorities having jurisdiction. Failure to do so may impair the performance of these devices.

The design of individual water spray fixed systems can vary considerably, depending on the characteristics and nature of the hazard, the basic purpose of the spraying system, the configuration of the hazard, and wind/draft conditions. Because of these variations as well as the wide range of available nozzle spray characteristics, the design of water spray fixed systems for fire protection must only be performed by experienced designers who thoroughly understand the limitations as well as capabilities of such systems.

The owner is responsible for maintaining their fire protection system and devices in proper operating condition. Contact the installing contractor or product manufacturer with any questions.

MODEL NUMBER	K-FACTOR		A NOMINAL LENGTH in. (mm)	B FACE OF NOZZLE FITTING in. (mm)	COLOR CODE
	NFPA gpm/psi ^{1/2}	ISO/SI lpm/bar ^{1/2}			
F822	2.0	28,8	1-5/8 (42)	1-1/8 (28,6)	YELLOW
F824	2.3	33,1			RED
F826	2.6	37,4			ORANGE
F828	2.7	38,9	1-11/16 (43)	1-3/16 (30,2)	WHITE
F832	4.6	66,2	1-13/16 (47)	1-5/16 (33,3)	ALUMINUM
F834	5.1	73,4	2-3/4 (70)	2-1/4 (57,2)	GRAY

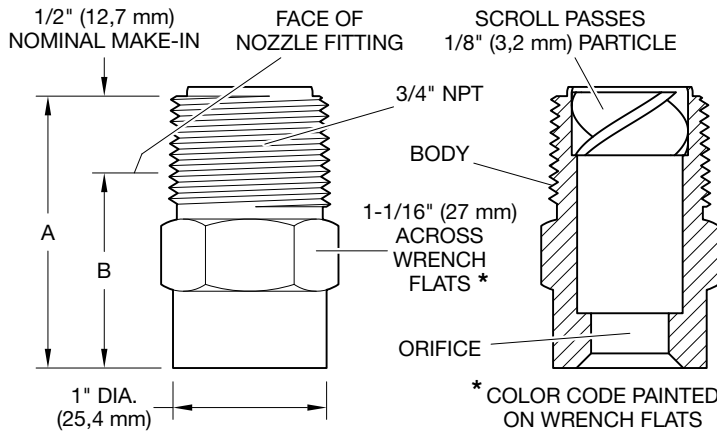

FIGURE 1
MODEL F822 THRU F834 MULSIFYRE NOZZLES
NOMINAL DIMENSIONS

Technical Data

Approvals
UL and ULC Listed

Maximum Working Pressure
175 psi (12,1 bar).
Also see Graph A, Note 2

Discharge Coefficient
See Figure 1

Water Distribution
Optimum flow pressure is 30 to 60 psi (2,1 to 4,1 bar). See Graph A (1 of 2).

Thread Connection
3/4 inch NPT

Physical Characteristics (Basic Nozzle)

BodyBrass
ScrollBrass

Physical Characteristics (Nozzle with Dust Cap)

Body Chrome Plated Brass
ScrollBrass
Dust Cap EPDM
Retaining Wire Stainless Steel

Design Criteria

Nozzle Placement

Where direct impingement of water spray onto all of the protected surface

is required by the authority having jurisdiction, the nozzles are to be spaced and directed so that their spray patterns will completely cover the plane-of-protection with the minimum required average density. With reference to Graph A (1 of 2), use of the Design Spray Profile for the Design Spray Area will help assure that direct impingement on all surfaces will occur. The Design Spray Area shown at the top Graph A (2 of 2) consists of the square of length "S" within the circular Overall Spray Area.

The maximum recommended axial distances given in Graph A (2 of 2) are based on maintaining the specified spray patterns under a maximum wind condition of 15 MPH (24 km/h).

Dust Caps

The Model F880 Dust Caps are rated for indoor and outdoor use over a temperature range of -60°F to 150°F (-51°C to 65°C). A minimum residual (flowing) pressure of 15 psi (1,0 bar) is required to assure release of the dust cap.

Main Pipeline Strainers

Main pipeline strainers per NFPA 15 are required for systems utilizing MULSIFYRE Nozzles since their waterways are less than 3/8 inch (9,5 mm) diameter. Individual strainers are not required since the openings in the scrolls will pass a 1/8 inch (3,2 mm) particle.

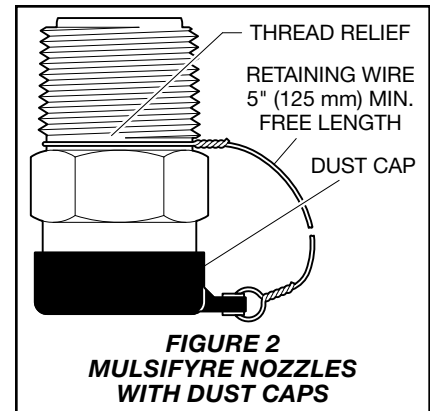

FIGURE 2
MULSIFYRE NOZZLES
WITH DUST CAPS

Installation

MULSIFYRE Nozzles must be installed in accordance with this section.

General Instructions

A leak tight 3/4 inch NPT nozzle joint should be obtained with a torque of 10 to 20 ft-lbs. (13,4 to 26,8 N·m). Higher levels of torque may distort the nozzle inlet and cause leakage or impairment of the nozzle.

Step 1. With pipe thread sealant applied to the pipe threads, hand tighten the nozzle into the nozzle fitting.

Step 2. Tighten the nozzle into the nozzle fitting using an adjustable crescent wrench. With reference to Figure 1 apply the adjustable crescent wrench to the nozzle wrench flats.

Replacement Dust Caps

When replacement dust caps are installed, there is to be a minimum of 5 in. (125 mm) of wire, see Figure 2, between the wire loop point at the nozzle thread relief and attached to the dust cap. The minimum length of 5 in. (125 mm) will help to assure that there will be an unrestricted flow from the nozzle outlet during operation.

Care and Maintenance

The MULSIFYRE Nozzles must be maintained and serviced in accordance with this section.

Before closing a fire protection system main control valve for maintenance work on the fire protection system that it controls, permission to shut down the affected fire protection system must be obtained from the proper authorities and all personnel who may be affected by this action must be notified.

MULSIFYRE Nozzles must never be painted, plated, coated or altered in any way after leaving the factory; otherwise, the spray performance may be impaired.

NOTES:

1. Data applies to a maximum wind condition of 15 MPH (24 km/h).
2. Data applies to a residual (flowing) pressure range at the nozzle inlet of 30 to 60 psi (2,1 to 4,1 bar). (For pressures up to 175 psi (12,1 bar) consult Johnson Controls Technical Services.)
3. The shapes of the Design Spray Profiles remain essentially unchanged over the maximum recommended axial distance and the residual (flowing) pressure range of 30 to 60 psi (2,1 to 4,1 bar).

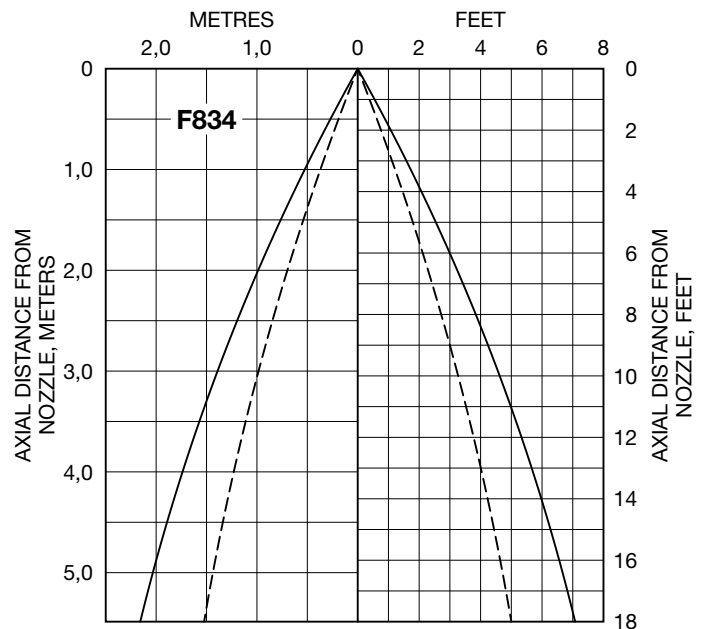
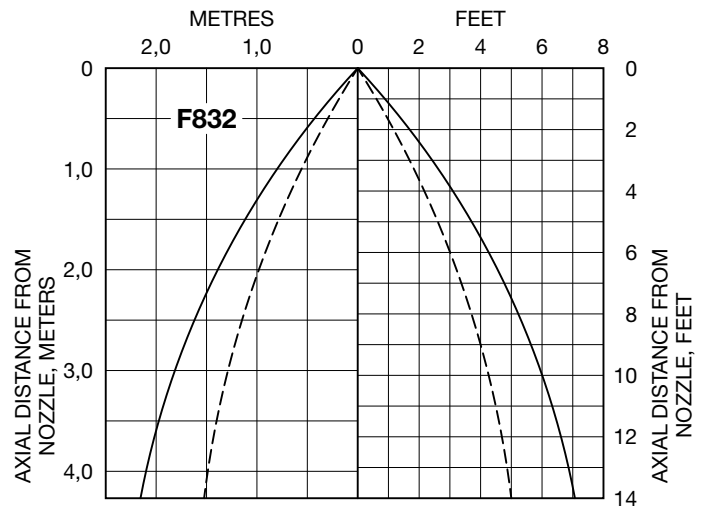
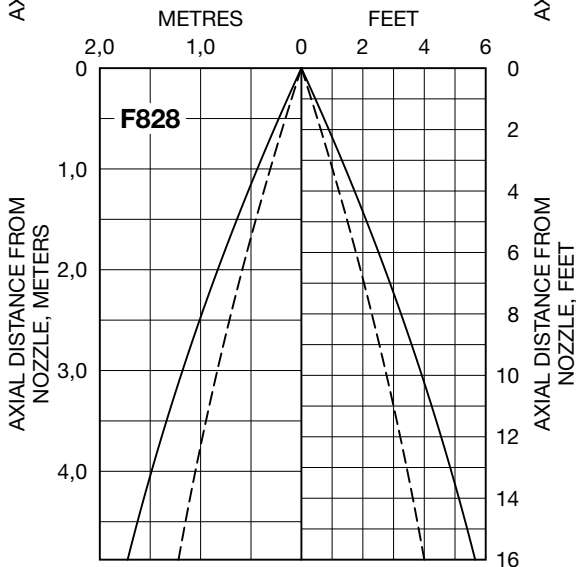
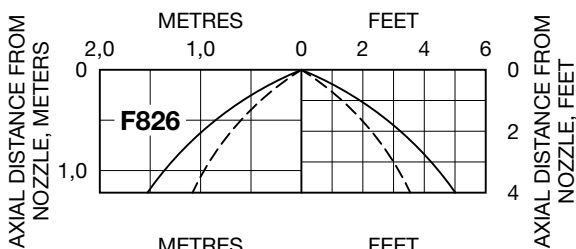
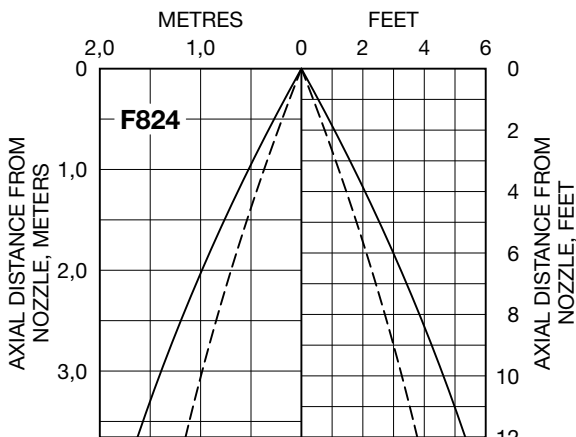
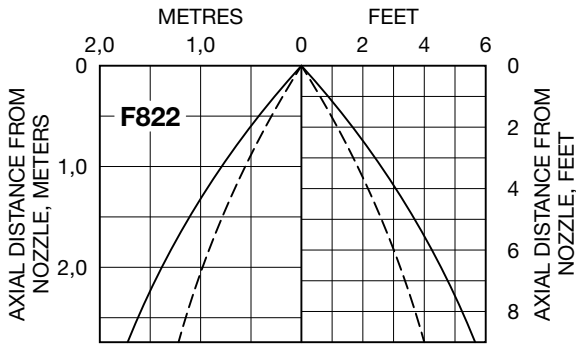
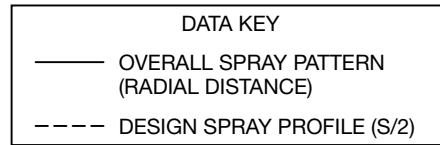

GRAPH A (1 OF 2)
WATER DISTRIBUTION DESIGN DATA

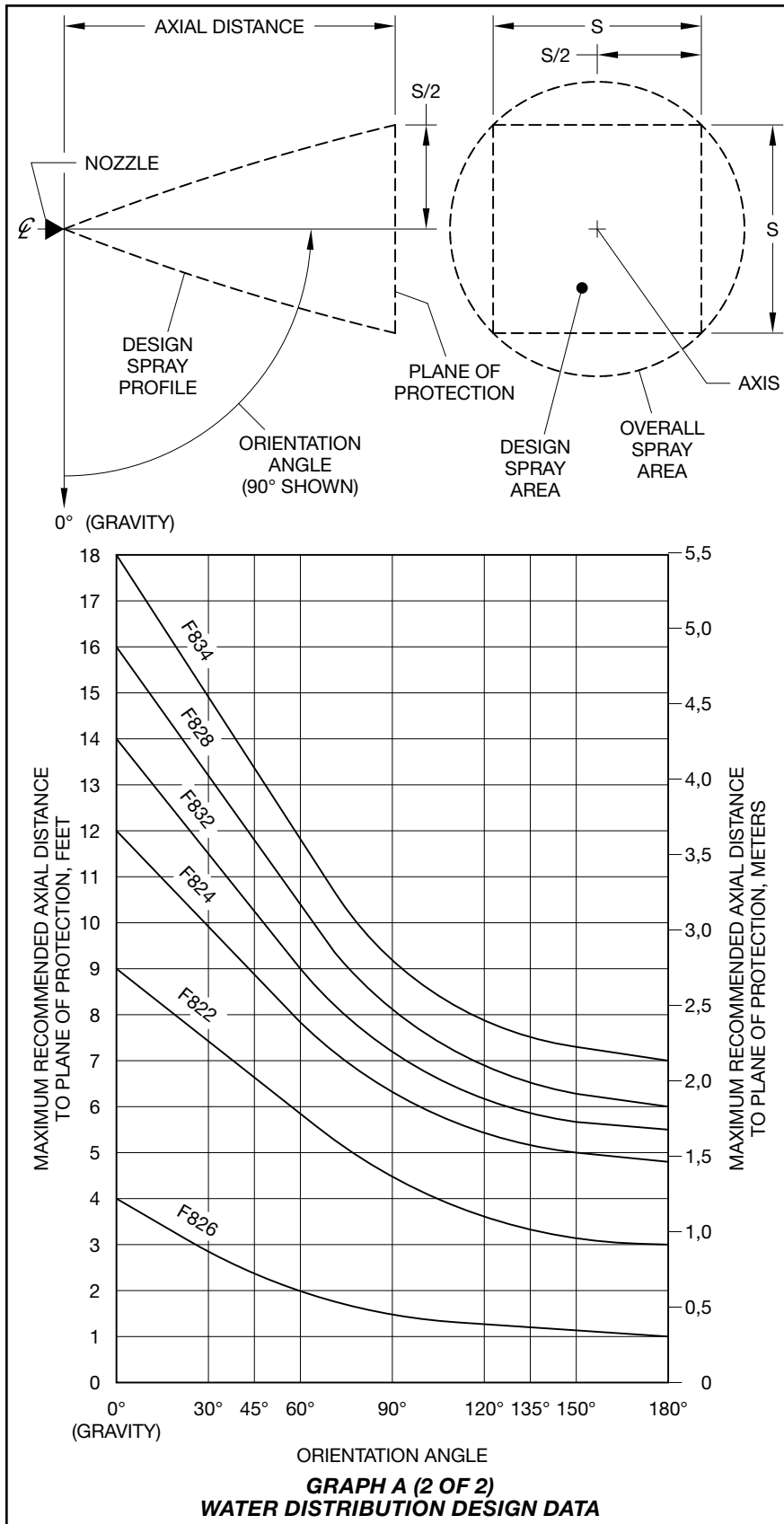

Care must be exercised to avoid damage to the nozzles before, during, and after installation. Nozzles damaged by dropping, striking, wrench twist/slip-page, or the like, must be replaced.

Frequent visual inspections are recommended to be initially performed for nozzles installed in potentially corrosive atmospheres to verify the integrity of the materials of construction as they may be affected by the corrosive conditions present for a given installation. Thereafter, annual inspections per NFPA 25 are required.

Water spray fixed systems for fire protection service require regularly scheduled care and maintenance by trained personnel. In addition to inspecting nozzles for proper spray performance during water flow trip tests of the system, it is recommended that nozzles be periodically inspected for broken or missing parts (including dust caps where applicable), loading/obstructions, or other evidence of impaired protection. The inspections should be scheduled weekly or as frequently as may be necessary, and corrective action must be taken to ensure that the nozzles will perform as intended in the event of a fire.

For installations subject to freezing and where dust caps have been installed, a periodic inspection must be performed for evidence of ice build-up from trapped condensate which could affect the proper release of the dust cap.

The owner is responsible for the inspection, testing, and maintenance of their fire protection system and devices in compliance with this document, as well as with the applicable standards of the NATIONAL FIRE PROTECTION ASSOCIATION (e.g., NFPA 25), in addition to the standards of any other authorities having jurisdiction. Contact the installing contractor or product manufacturer with any questions.

It is recommended that water spray fixed systems be inspected, tested, and maintained by a qualified Inspection Service in accordance with local requirements and/or national codes.

Limited Warranty

For warranty terms and conditions, visit
www.tyco-fire.com.

Ordering Procedure

Contact your local distributor for availability. When placing an order, indicate the full product name and P/N.

MULSIFYRE Nozzles

Specify: Model (number) MULSIFYRE Nozzle, P/N (specify):

Model F822	49-800-1-822
Model F824	49-800-1-824
Model F826	49-800-1-826
Model F828	49-800-1-828
Model F832	49-800-1-832
Model F834	49-800-1-834

MULSIFYRE Nozzles with Model F880 Dust Cap

Specify: Model (number) MULSIFYRE Nozzle with Model F880 Dust Cap, P/N (specify):

Model F822	49-801-1-822
Model F824	49-801-1-824
Model F826	49-801-1-826
Model F828	49-801-1-828
Model F832	49-801-1-832
Model F834	49-801-1-834

Replacement Parts

Specify: Model F880 Dust Cap Assembly, P/N 56-880-1-001

NOTE: *The Model F880 Dust Cap may only be used for replacement on MULSIFYRE Nozzles with chrome plated bodies. Otherwise failure for the dust cap to release may occur with resulting impairment of the system.*

Specify: Blow-Off Cap Assembly for use with discontinued Model F822B through F834B MULSIFYRE Nozzles, P/N 56-802-1-001

NOTE: *The Blow-Off Cap Assembly may only be used with the previously offered Model F822B through F834B MULSIFYRE Nozzles.*



Worldwide
Contacts | www.tyco-fire.com

TFP810 Change History Appendix

ISSUE DATE	NOTES
08-22	Page 1, added QR code and URL to allow convenient access to electronic version from printed document; Page 6, changed corporate address and telephone number to 1467 Elmwood Avenue, Cranston, RI 02910 Telephone +1-401-781-8220, formerly 1400 Pennbrook Parkway, Lansdale, PA 19446 Telephone +1-215-362-0700.
08-18	Updated Tyco® branding and document format; Added Johnson Controls copyright; Added disclaimer stating specifications and information subject to change without notice; Added reference to Regulatory and Health Warning Technical Data Sheet TFP2300.
10-15	Removed FM Approved; Changed UL Listed and ULC Listed.
02-14	Changed Model F826 K-factor to 2.6 (37,4), formerly shown as 2.7 (38,9); Changed Model F828 K-factor to 2.7 (38,9), formerly shown as 2.6 (37,4).
04-06	New Technical Data Sheet TFP810 describes Models F822 to F834 Mulsifyre Nozzles.