

DDS Duct Deluge System For The Protection of Ventilation Ductwork Handling Corrosive Gases

General Description

The TYCO DDS Duct Deluge System is designed specifically for the protection of ventilation ductwork handling corrosive gases, including extremely corrosive gases as defined in FM Property Loss Prevention Data Sheet 7-78.

The DDS System features the TYCO DN-5 Corrosion Resistant Duct Nozzle, which is an open (non automatic) directional spray nozzle, and also includes the TYCO Red-E Cabinet, Protectowire linear heat detection, and FlexHead duct mounting hardware. The DDS System is capable of achieving fire suppression and potential extinguishment in ventilation ductwork constructed of plastic material. The DDS System benefits include limiting down-time due to fire damage and routine inspection and maintenance.

Ventilation ductwork handling extremely corrosive environments may be encountered in the following industrial settings:

- Steel Manufacturing
- Copper Mineral Processing
- Lead Mineral Processing
- Zinc Mineral Processing
- Coal Power Generation
- Semiconductor Fabrication
- Pulp & Paper Facilities

CAUTION

This system is unique in its intent and design. Anyone involved at any level must thoroughly understand the limitations and capabilities of such systems.

NOTICE

The DDS System described herein must be installed and maintained in compliance with this document, FM Global Property Loss Prevention Data Sheets, the applicable standards of the National Fire Protection Association, in



addition to the standards of any other authorities having jurisdiction. Failure to do so may impair the performance of this system.

The owner is responsible for maintaining their fire protection system and devices in proper operating condition. Contact the installing contractor or product manufacturer with any questions.

Approvals & Application Criteria

The components of the TYCO DDS Duct Deluge System are Factory Mutual (FM) Approved for use in extremely corrosive environments.

The DDS System is intended for use in plastic ventilation ductwork constructed of Fiber-Reinforced Plastic (FRP), Polyvinyl Chloride (PVC), or Polypropylene (PP), which may be circular, rectangular, or irregular in shape. Duct diameter or width may range from 1 ft. to 16 ft.

Protection Objectives

The TYCO DDS Duct Deluge System is intended to reduce fire hazards inherent in industrial exhaust systems and prevent fire spread via these systems, whether within buildings or between adjacent buildings.

The DDS System components are capable of withstanding environments in which extremely corrosive gases may be present, including but not limited to:

- Hydrochloric acid (HCL)
- Hydrofluoric acid (HF)
- Sulfuric Acid (H₂SO₄)
- Nitric Acid (HNO₃)
- Sulfur Dioxide (SO₂)

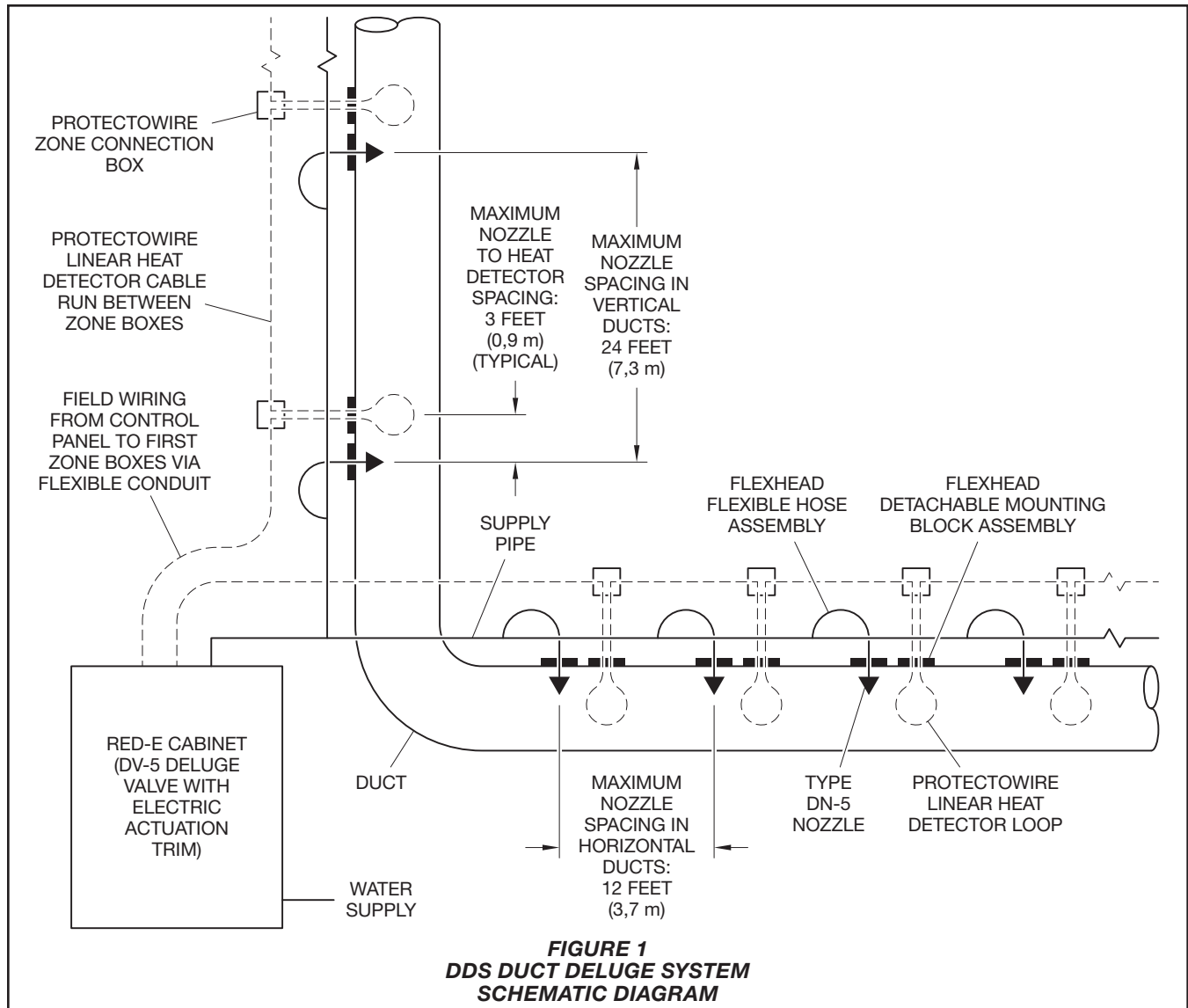

System Components

Nozzle

TYCO Type DN-5 Corrosion Resistant Duct Nozzle with HALAR (ECTFE) coating. This component is described in Technical Data Sheet TFP808.

Deluge Valve and Releasing Control Panel

TYCO DV-5 Red-E Cabinet with Electric Actuation. This component is described in Technical Data Sheet TFP1300.

Installation Hardware

FlexHead HALAR Mounting System. Installation and maintenance procedures for this component are described in:

- FlexHead Duct Sprinkler
- FRP Ductwork Model Installation and Maintenance Manual
- PVC Ductwork Model Installation and Maintenance Manual
- Polypropylene Ductwork Model Installation and Maintenance Manual

PROTECTOWIRE Linear Heat Detection

This component is described in PROTECTOWIRE data sheet "DS-6592 PWC". Installation and maintenance procedures for this component are described in:

- Protectowire Linear Heat Detector Installation, Operation & Maintenance Manual
- Duct Deluge Linear Heat Detector Installation Instructions for Part Number PDK-1
- DS-6592 PWC

System Design Criteria

Hydraulic Requirements

Base the water supply on a design of 20 gpm (75,7 lpm) per nozzle for ducts less than 4 ft. (1,2 m) in diameter or width. Design for 30 gpm (113,6 lpm) per nozzle for ducts 4 ft. to 8 ft. (1,2 m to 2,4 m) in diameter or width.

Ducts that are greater than 8 ft. to 16 ft. (2,4 m to 4,9 m) in diameter or width require two nozzles at each plane of installation. Base the water supply on a design of 20 gpm (75,7 lpm) per nozzle, 40 gpm (151,4 lpm) total at each plane of installation.

Refer to Figure 4 for additional detail.

For ducts exceeding 16 ft. (4,9 m) in diameter, contact your local authority having jurisdiction or the engineer of record.

System Functional Description	Model	Description	Data Sheet and Installation Instruction	Size	Temperature Rating
Nozzles	Type DN-5 Nozzle	HALAR Coated Stainless Steel Nozzle	TFP808	-	-
Deluge Valve and Releasing Control Panel	TYCO Red-E Cabinet	Electric Actuation Deluge with Galvanized Trim	TFP1300	1-1/2 Inch	-
				2 Inch	
				3 Inch	
				4 Inch	
				6 Inch	
Nozzle and LHD Installation Methodology	FlexHead Special FRP/HALAR Duct System	HALAR Upper Mounting Block with FRP, PP, or PVC Lower Mounting Block and a Viton Gasket	FlexHead Duct Sprinkler Installation and Maintenance for FRP Ductwork Model Installation and Maintenance for PP Ductwork Model Installation and Maintenance for PVC Ductwork Model	2 ft. Hose	-
				3 ft. Hose	
				4 ft. Hose	
				No Hose For Use with LHD	-
Linear Heat Detection	PROTECTOWIRE Type XCR Construction	Fluoropolymer Jacket Linear Heat Detector	Protectowire Linear Heat Detector Installation, Operation & Maintenance Manual Duct Deluge Linear Heat Detector Installation Instructions for Part Number PDK-1 DS-6592 PWC	100 ft. min.	190°F for max. 150°F
	PROTECTOWIRE PDK-1 Installation Kit	One kit required for each LHD insertion point			-
TABLE A DDS DUCT DELUGE SYSTEM COMPONENTS					

Nozzle Placement

Install the TYCO Type DN-5 Corrosion Resistant Duct Nozzle no more than 12 ft. (3,7 m) on center in horizontal ducts, and 24 ft. (7,3 m) on center (preferably at the top) in vertical ducts. Refer to Figure 3 and 4 for positioning details.

NOTICE

Install a Type DN-5 Corrosion Resistant Duct Nozzle at the top of every vertical run of duct, as close as possible to the transition from vertical to horizontal.

The maximum continuous operating temperature should not exceed 302°F (150°C).

Detection Placement

Install a loop of Protectowire linear heat detection cable inside the duct at the same maximum spacing as the nozzles. Locate the loops within 3 ft. (0,9 m) of the nozzles. Refer to Figure 1 for placement details and Figure 5 for installation details.

NOTICE

Install a loop of Protectowire linear heat detection cable at the top of every vertical run of duct, as close as possible to the transition from vertical to horizontal.

Water Delivery

Water delivery time (from initial detector activation to full discharge from all nozzles) is not to exceed one minute. Refer to FM Data Sheet 7-78 for further detail.

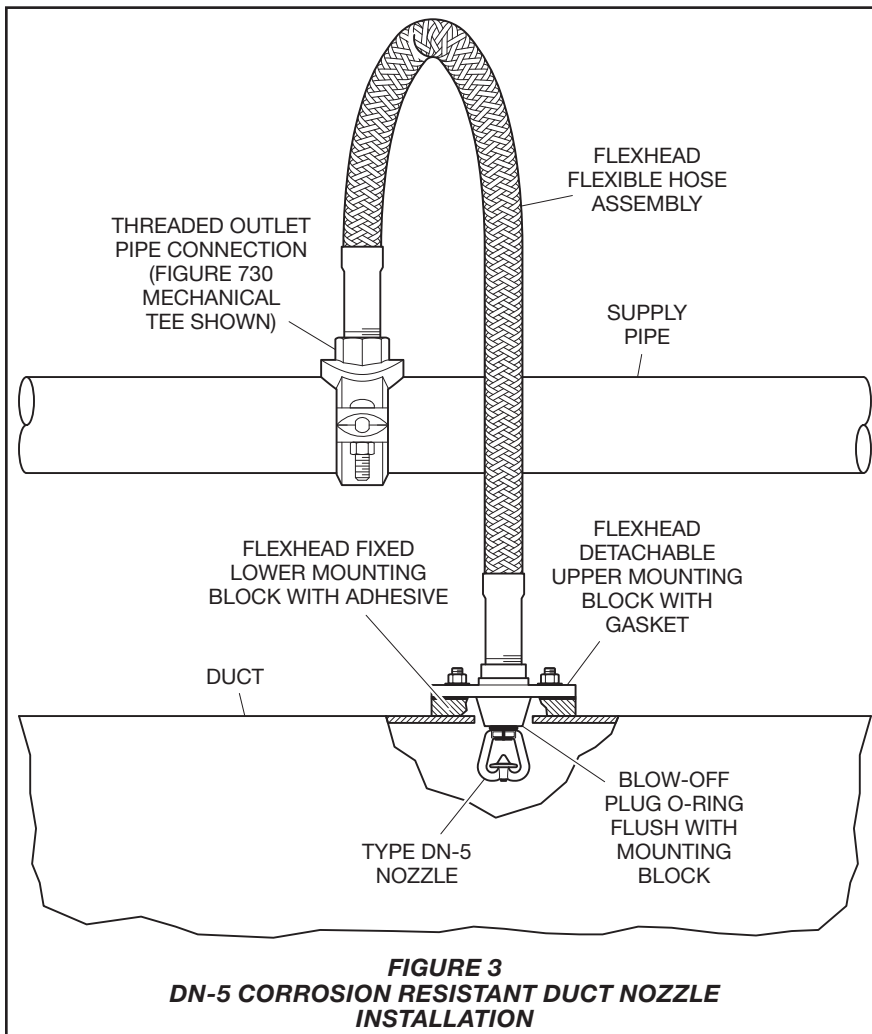
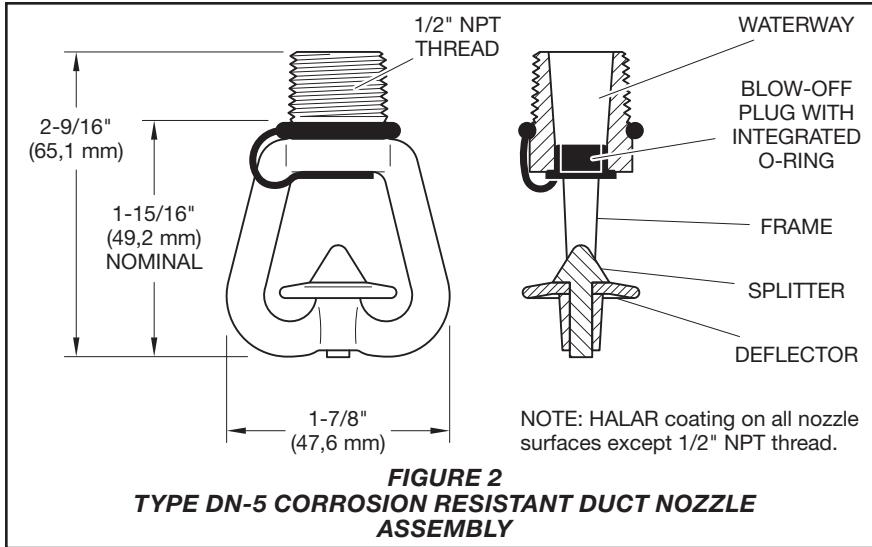

Nozzle Installation Instructions

The TYCO Type DN-5 Corrosion Resistant Duct Nozzles must be installed in accordance with this section.

Step 1. With pipe-thread sealant applied to nozzle pipe threads, hand tighten nozzle into Mounting Block until the O-Ring makes contact with the Mounting Block Sealing Surface, then continue hand tightening the nozzle another 1/4 to 1/2 turn.

CAUTION

Do not hand tighten more than 1/4 to 1/2 turn once the Type DN-5 Nozzle is seated to the Mounting Block Sealing Surface. Over-tightening may result in equipment failure.

Use of a metal wrench when installing the Type DN-5 Nozzle may damage the nozzle coating and decrease the nozzle corrosion resistance.

Step 2. Ensure Type DN-5 Nozzle O-Ring is firmly seated between Nozzle and Mounting Block Sealing Surface. Correctly installed O-Ring forms a seal around the Type DN-5 Nozzle pipe threads.

Step 3. Ensure Blow-Off Plug is fully seated into nozzle waterway.

Care and Maintenance

The TYCO DDS Duct Deluge System must be maintained and serviced in accordance with this section.

Before closing a fire protection system control valve for inspection or maintenance work, obtain permission to shut down the affected fire protection system from the proper authorities and notify all personnel who may be affected by this action.

Exercise care to avoid damage to the TYCO DDS Duct Deluge System components before, during, and after installation. Replace components damaged by improper handling, dropping, striking, or the like.

Water spray systems for fire protection service require regularly scheduled care and maintenance by trained personnel.

NOTICE

It is recommended that TYCO DDS Duct Deluge System components be inspected six months after installation. Inspect components located in

HYDRAULIC REQUIREMENTS			
D DUCT SIZE FEET (METERS)	NOZZLE QTY	NOZZLE POSITION	FLOW EACH NOZZLE GPM (LPM)
Less than 4 (1,2)	1	X	20 (75,7)
4 (1,2) TO 8 (2,4)	1	X	30 (113,6)
Greater than 8 (2,4) to 16 (4,9)	2	Y and Z	20 (75,7)

- NOTES:**
1. MEASURED ALONG SURFACE CONTOUR OF DUCT
 2. CONTACT FM APPROVALS FOR APPLICATIONS REQUIRING GREATER VARIATION

POSITION VARIATION			
D DUCT SIZE FEET (METERS)	X NOMINAL POSITION	A MAXIMUM VARIATION ²	
	DEGREES	DEGREES	INCHES ¹ (CM)
2 (0,6)	0	30	6.25 (15,9)
4 (1,2)	0	30	12.63 (32,1)
6 (1,8)	0	30	18.81 (47,8)
8 (2,4)	0	30	25.06 (63,7)

POSITION VARIATION				
D DUCT SIZE FEET (METERS)	Y AND Z NOMINAL POSITION		A MAXIMUM VARIATION ²	
	DEGREES	INCHES ¹ (CM)	DEGREES	INCHES ¹ (CM)
10 (3,0)	60	62.81 (159,6)	10	10.43 (26,5)
12 (3,7)	60	75.38 (191,5)	10	12.50 (931,8)
14 (4,3)	60	88.00 (223,4)	10	14.63 (37,1)
16 (4,9)	60	100.50 (255,4)	10	16.75 (42,5)

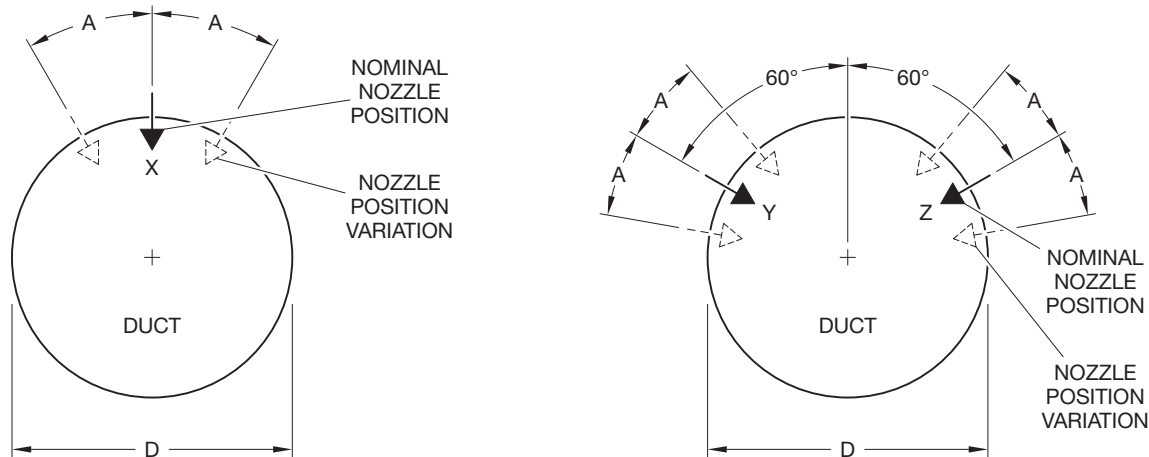

**FIGURE 4
NOZZLE HYDRAULIC REQUIREMENTS
AND POSITION VARIATION**

the area of highest chemical concentrations, near the beginning of the process duct. Inspect components annually thereafter unless damage to the coating is noted. Inspect for damage due to corrosion, deterioration of the coated surfaces of components, improper orientation, or other evidence of impaired protection per the methodology described in the Protection for Ducts in Extremely Corrosive Environments section of FM Data Sheet 7-78.

After placing a fire protection system in service, notify the proper authorities and advise those responsible for monitoring proprietary and/or central station alarms.

The owner is responsible for the inspection, testing, and maintenance of their fire protection system and devices in compliance with this document, as well as with the applicable requirements of FM Global Property Loss Prevention Data Sheets, the applicable standards of the National Fire Protection Association, in addition to the standards of any other authorities having jurisdiction. Failure to do so may impair the performance of this system.

Contact the installing contractor or product manufacturer with any questions.

Limited Warranty

For warranty terms and conditions, visit www.tyco-fire.com.

